

# NEXUS

NEW TIMES MAGAZINE

Volume 4, Number 4 JUNE - JULY 1997

PO Box 30, Mapleton Qld 4560, Australia

## CONTENTS

LETTERS TO THE EDITOR.....4	THE SECRET LIVES OF FRANCIS BACON.....53
GLOBAL NEWS.....6	<i>By Michael Taylor. Sir Francis Bacon used pen-names and ciphers to conceal what he thought should be kept secret. Some of his finest work was written under the name of William Shakespeare.</i>
<i>A round-up of the news you probably did not see.</i>	THE TWILIGHT ZONE.....61
WHY SCHOOLS DON'T EDUCATE.....13	<i>Strange tales from around/within/off the world. This issue we feature Dr Steven Greer's report on CSETI's UFO briefings, held recently in Washington, DC.</i>
<i>By John Taylor Gatto. An award-winning teacher explains what's wrong with schooling, but his solution involves a paradigm shift that encourages individual self-reliance balanced with family input.</i>	THE 'CHUPACABRAS' MYSTERY.....65
THE PEGASUS FILE—Part 2.....19	<i>By Linda Moulton Howe. Terrifying vampire-like attacks on animals and humans were reported in Puerto Rico, Mexico and southern USA in 1995-96. Are chupacabras to blame? Did UFOs bring them?</i>
<i>By David G. Guyatt. Former deep-cover agent "Chip" Tatum continues his exposé on the "Boss Hogs" who control lucrative drug-running and money-laundering operations around the world.</i>	REVIEWS—Books.....71
A BITTER PILL TO SWALLOW.....25	<i>"The Roswell Message" by René Coudris</i>
<i>By Sherrill Sellman. Contrary to mainstream medical opinion, the contraceptive Pill has a tragic downside for women, for it is implicated in an A to Z of side-effects including cancer and infertility.</i>	<i>"Master R: Lord of Our Civilisation" by Michael Taylor</i>
THE BIO-ELITES: ENGINEERING OUR FUTURE.....31	<i>"Enter the Vortex as One Light" by Sizzond Zadore (Jon Whistler)</i>
<i>By Susan Bryce. The latest developments in human biotechnology promote profit at the expense of genetic heritage and privacy, despite all the promised benefits of the gene revolution.</i>	<i>"Sounding the Inner Landscape" by Kay Gardner</i>
AN ELECTROMAGNETIC CANCER TREATMENT.....37	<i>"The God Hypothesis" by Joe Lewels, Ph.D.</i>
<i>By John Chambers. Dr Jerry Jacobson has conceived a radical approach to treating cancer, but believes his efforts to secure R&amp;D funding have been deliberately obstructed by powerful interests.</i>	<i>"Colloidal Silver: The Hidden Truths" by Keith F. Courtenay</i>
BRIGHT SKIES—Part 2.....43	<i>"Miracles" by Cassandra Eason</i>
<i>By Harry Mason. Strange light-energy bursts and beams seen recently over remote parts of Western Australia are quite probably associated with Tesla-style scalar weapons testing. What is the purpose?</i>	<i>"Alternative 4: UFOs, Mind &amp; Body Control" by Alder</i>
NEW SCIENCE NEWS.....49	<i>"Who Killed the Darling Buds of May?" by Catherine O'Driscoll</i>
<i>A selection of interesting news and views from the underground science network. Here, Pierre Sinclair shows how to build the Gravito-Magnetic Device (GMD) as first developed by David Hamel.</i>	<i>"The Shadow of Atlantis" by Alexander Braghine</i>
	<i>"The Benefactor's Monkey" by Christopher Morten</i>
	<i>"Ancient Tonga &amp; the Lost City of Mu'a" by David Hatcher Childress</i>
	<i>"Beyond Roswell" by Michael Hesemann and Philip Mantle</i>
	<i>"Betrayal of the Spirit" by Nori J. Muster</i>
	<i>"Children of a Toxic Harvest" by Eve Hillary</i>
	REVIEWS—Lecture Tape.....78
	<i>"The Secrets of the Vatican" with Simon Treselyan</i>
	REVIEWS—Video.....78
	<i>"Australian International UFO Symposium, Vols. 1-12"</i>
	REVIEWS—Audio.....79
	<i>"Acoustic Research Series" by Dr Jeffrey Thompson</i>
	<i>"Bio-Energetic Psychotropic Music" by Boris Mourashkin</i>
	<i>"Harmonic Resonance" by Jim Oliver</i>
	<i>"Healing Key" by SPIN.FX</i>
	<i>"Naked Didge" by Dr Didge</i>
	NEXUS BOOKS, SUBS, ADS & VIDEOS.....97

# NEXUS MAGAZINE

Volume 4, Number 4

JUNE - JULY 1997

PUBLISHED BY

NEXUS Magazine Pty Ltd, ACN #003 611 434

EDITOR

Duncan M. Roads

CO-EDITOR

Catherine Simons

ASSISTANT EDITOR

Ruth Parnell

EDITORS' ASSISTANT

Richard Giles

OFFICE ADMINISTRATOR

Janine Carmichael

CONTRIBUTORS THIS ISSUE

John Taylor Gatto, David G. Guyatt,  
Sherrill Sellman, Susan Bryce, John Chambers,  
Harry Mason, Pierre Sinclair, Michael Taylor,  
Steven Greer, MD, Linda Moulton Howe

LAYOUT & DESIGN

Duncan M. Roads

CARTOONS

Phil Somerville

COVER GRAPHIC

Alex Clarke Graphic Design, Lismore, NSW

PRINTING

Warwick Daily News, Queensland, Australia

AUSTRALIAN DISTRIBUTION

Newsagents Direct Distribution

HEAD OFFICE - All Correspondence

PO Box 30, Mapleton, QLD 4560, Australia.

Ph: +61 (0)7 5442 9280; Fax: +61 (0)7 5442 9381

e-mail address: [nexus@peg.apc.org](mailto:nexus@peg.apc.org)

web page: <http://www.peg.apc.org/~nexus/>

NEW ZEALAND OFFICE - PO Box 306,

Westpark Village, West Harbour, Auckland.

Ph: +64 (0)9 416 7320; Fax: +64 (0)9 416 7340

USA OFFICE - PO Box 177, Kempton, IL 60946-

0177. Ph: (815) 253 6464; Fax: (815) 253 6454

UK OFFICE - 55 Queens Rd, East Grinstead, West

Sussex, RH19 1BG. Ph: +44 (0)1342 322854;

Fax: +44 (0)1342 324574

EUROPE OFFICE - PO Box 372, 8250 AJ Dronten,

The Netherlands. Ph: +31 (0)321 380558;

Fax: +31 (0)321 318892

ITALY OFFICE - c/- Avalon Edizioni,

Piazza Mazzini 52, 35137 Padova.

Ph/Fax: +39 (0)49 912 6006

STATEMENT OF PURPOSE

NEXUS recognises that humanity is undergoing a

massive transformation. With this in mind,

NEXUS seeks to provide 'hard-to-get' information

so as to assist people through these changes.

NEXUS is not linked to any religious, philosophical

or political ideology or organisation.

PERMISSION-TO-REPRODUCE POLICY

While reproduction and dissemination of the

information in NEXUS is actively encouraged,

anyone caught making a buck out of it, without

our express permission, will be in trouble when

we catch them!

## Editorial

*This editorial is going to address an issue that I have long bitten my tongue on, and that is the subject of various media attacks on myself and NEXUS.*

*These attacks all focus on one point, and that is they allege that I am a right-wing extremist and that NEXUS has a right-wing political agenda.*

*Until now, I had considered that it was unnecessary to defend myself in the pages of my own magazine, as it should be obvious to anyone reading NEXUS that there is nothing right-wing in or about it.*

*But, since there is an increasing amount of published information being recycled by journalists who don't do their job by checking facts, I find it necessary to explain myself to readers who are probably becoming curious as to why these allegations continue to surface.*

*Nearly all of the information attacking me and NEXUS has stemmed from a writer who works variously for the Fairfax media and is also listed as a contributor to Australia-Israel Review, a publication regarded as extreme right-wing even by Melbourne's Jewish community, as evidenced by documents in my possession.*

*This person, who will remain nameless here (on advice from my solicitor), spends a lot of time making the bullets that other more gullible journalists seem content to shoot.*

*Journalists in this category (if you can call them journalists) include Phillip Adams of ABC Radio National (who periodically insists that NEXUS is part of a right-wing neo-age conspiracy); and Matthew Kalman and John Murray, of Open Eye magazine in the UK, who wrote a lengthy article published in New Statesman linking the neo-age movement to neo-Nazis and citing NEXUS magazine as the proof. Kalman and Murray even went to the expense of printing up leaflets full of details of NEXUS' supposed right-wing, neo-Nazi connections.*

*Not one of my accusers has ever bothered to contact me personally to clarify any of the accusations they cheerfully regurgitate. It is patently clear that these people are not interested in the truth: they just want to cause trouble. In the UK it has gotten to the stage where some shopkeepers selling NEXUS have been threatened with violence if they continue to sell the magazine.*

*What really hurts is that I used to respect Phillip Adams, Open Eye magazine and New Statesman. Now I am left wondering what other lies and smears these people and publications have spread.*

*So, for the record, when you hear the next wave of media allegations that I am trying to lead the whole neo-age movement into a Libya-based, neo-Nazi terrorist training camp, you'll know they are wrong.*

*I am not right-wing, my friends are not right-wing and NEXUS has no political agenda. I am not an anti-Semite, and I am not a Libyan secret agent. I am, however, an information anarchist—and proud of it!*

*Meanwhile, I would like to apologise to readers who were probably expecting a more inspiring editorial. Next time!*

*Duncan*

### WARRANTY AND INDEMNITY

Advertisers upon and by lodging material with the Publisher for publication or authorising or approving of the publication of any material INDEMNIFY the Publisher and its servants and agents against all liability claims or proceedings whatsoever arising from the publication and without limiting the generality of the foregoing to indemnify each of them in relation to defamation, slander of title, breach of copyright, infringement of trademarks or names of publication titles, unfair competition or trade practices, royalties or violation of rights or privacy AND WARRANT that the material complies with all relevant laws and regulations and that its publication will not give rise to any rights against or liabilities in the Publisher, its servants or agents and in particular that nothing therein is capable of being misleading or deceptive or otherwise in breach of the Part V of the Trade Practices Act 1974. All expressions of opinion are published on the basis that they are not to be regarded as expressing the opinion of the Publisher or its servants or agents. Editorial advice is not specific and readers are advised to seek professional help for individual problems.

© NEXUS New Times 1997



# Letters to the Editor ...

## ADL/Zionist Persecution

Dear Duncan: Thank the Lord for people like Professor Noam Chomsky, who I believe is Jewish, for lifting the lid on the arrogant and vicious activities of the ADL [Anti-Defamation League]. [See Global News, NEXUS 4/03.]

The ADL may present itself as a Civil Rights organisation but it is in fact a political movement, the sole interest of which is the defence of Israel's policies regardless of how they impact on other people, and the parent body is the international Zionist movement.

Anti-Semitism is the charge made against anyone at odds with Zionist policies, together with charges of Nazism and racism. Moshe Menhuin, Yehudi's father, was so labelled when he wrote a book on the decadence of Judaism in the 20th century!

It is perhaps pertinent to indicate that the Zionist movement does not represent the Jewish people *en masse*, and in fact probably represents a minority, many of whom were terrorised into supporting Zionism.

On 6 February 1994, the Central Rabbinical Congress of USA and Canada placed a notice in the *New York Times*, stating "...therefore, we declare that the Zionist state of Israel is not the legitimate representative of our people. Our position on the ceding of land is quite simple: any Jewish sovereignty over the Holy Land before the Messianic epoch is sinful and sure to lead to tragedy, and it is certainly absurd to sacrifice even one human life for this illegitimate State."

Terry Lane, a Melbourne broadcaster, suffered persecution from the Zionist movement when he commented unfavourably on the treatment of Arabs in Palestine. His right to free speech and the imparting of information to the public was not supported either by his employer or by the Australian Government. And the Zionist officials scream about oppression and victimisation!?

Sincerely, James I., Gold Coast, Qld, Australia.

## Psi-Power Protection

Dear Duncan: I have read the article, "The ESP of Espionage: Part 3" and enjoyed it [NEXUS 4/02]. It actually had me laughing at how weak these technologies are! I hope no one is too afraid.

To begin, we are all telepathic and we constantly carry out subvocalised conversations with people when we aren't around them. Sometimes we have real fights on a subvocal level—and we feel all the emotions as if we were talking to these people. If they are 'listening' (this need not be simultaneous; they may pick up your message later), they can answer. Thus a conversation continues.

I have studied my own experiences and taught myself, as many do, how to block other people's unpleasant messages so that I am switched off to their signals. This is done by intent. The physical brain switches off to a certain signal. Whether this signal is from a mind, or synthetic, it need not affect you.

The same goes for others trying to read your thoughts. There is no way anyone can if you don't want them to. You can shut down your broadcasting with intent. The human brain is a thousand times more powerful than any technology and we have every means given to us by nature to protect ourselves.

When I read the article I just had to laugh. It shows up all the weaknesses of the dark forces in government. They are so weak in their own psychic abilities that they have to develop technology to copy what they don't have! As far as I am concerned, they are playing their weak little games, pretending to be big and powerful when, really, they are afraid of their personal lack of power. They are very nicely teaching the rest of us how to find our own. As time goes on, the more I see this.

Kind regards, Linda A., Carrun, Victoria, Australia.

## Calling Spaceship Perth!

Dear Duncan: I greatly enjoy reading the NEXUS magazine. I have enclosed my cheque to start having it delivered instead of rummaging through the magazine stands at newsagents hoping to find a copy.

There is one thing I would like to do and that is to be able to discuss with others of like mind the type of articles appearing in your magazine.

I have tried to find the location of a group interested in paranormal activities here in Perth, without success, so who, if anyone, in Western Australia investigates

reports of UFOs and the like (other than the Air Force)?

If you have any information on suitable groups in the Perth area, please let me know. If there are none, I am prepared to use my home phone as a contact number for anyone who would like to join me in getting a group up and running here in the West.

Yours sincerely, Jane Saunders, Queens Park, Perth, Western Australia, ph/fax (09) 451 7485.

## Search for the JASON Society

Dear Duncan: Having succeeded the first time in getting a letter published in NEXUS, I will have another go.

In all the years I've been ferretting around to get behind at the truth, I have seen only two mentions of a secret society of scientists: the JASON Society. Does anybody out there have any information? Especially since we now have cloning in 'progress' and other man-made 'miracles', it is time to expose these varmints who obviously would like to remain nameless. One reference I have is from William Cooper's document, some years old by now, on the secret government.

When I hung out with New-Agers about 15 years ago, there was a persistent story doing the rounds, that many of today's scientists had been living during the time of Atlantis, and that their nefarious experiments on man/animal hybrids were a cause of that country being destroyed. The expressed idea these folk had (they believed in reincarnation) is that today's scientists are being given another chance 'this time around' to clean up their act. Anyone for spilling the beans on the JASON Society?

Thanks for being there; I find some very interesting things in NEXUS.

Devra S., Kippa Ring, Queensland, Australia.

## Cold War Conspiracy

Dear Mr Roads: I am a new subscriber to NEXUS, having seen the Dec'96-Jan'97 issue on a newsstand and being intrigued by "Major Jordan's Diary" [NEXUS 4/01, 4/02].

That article concludes with a comment on "a policy of appeasement of Russia from which we have never recovered and from

which we are still suffering". The question is, why the policy of appeasement? It was decidedly not because of fellow travellers in the State Department and other branches of the US Government. That was carefully-constructed disinformation.

The appeasement (if that is the proper word) came from the very top corporate-industrial leadership. Its purpose was to ensure the survival of the USSR, without which there could not have been a Communist menace and a Cold War. Its purpose was to keep the US economy on a war footing for 50 years after World War II, thus producing immense profits for the ruling elites and creating a crypto-fascist national security state.

The Cold War was the biggest con job in history.

Sincerely, John S., Lubbock, Texas, USA.

## Pet Food Pessimism?

Dear Sir: Thank you for your informative article about pet foods [see NEXUS 4/01]. It is great to be informed. However, I would like to point out that when I, and I'm sure many others, read such articles we are left feeling angry and disillusioned. I feel that this is due to the fact that the articles do not follow up with any encouraging alternatives we can pursue.

Would it not be possible for your writers to spend 10 per cent of the energy they put into their articles researching positive alternatives so we are not left 'high and dry' and depressed after reading your magazine? Actually, I do not subscribe to your magazine for just that reason. Someone happened to give me this article, though I have read your magazine before as my brother always gets it and I find his negative repertoire distressing.

If he could end his stories positively, wouldn't that contribute to our push towards a more harmonious and peaceful life, where we are trying to take action to rectify these wrongs?—something I am sure you are striving for.

Please help by giving us the tools we need. I am writing this as a suggestion and observation, not a criticism.

Anna H., Gerroa, New South Wales, Australia.

[Dear Anna: Please turn to Global News in this issue for a suggested alternative to manufactured pet foods. Ed.]

# ... more Letters to the Editor

NB: Please keep letters to approx. 100-150 words in length. Ed.

## Fasting for Freedom

Dear Duncan: Re your Editorial in Feb/March'97 issue where you talk about how we dutifully absorb the rubbish "They" throw at us, I've found a periodic short fast (up to one and a half days) a great way to get myself back from feeling that other people are trying to own me. It helps me feel free on all levels. I can walk past 'food' shops and other shops and think, "I am free of all this." It's a marvellous feeling in every way.

(Health note: I'm not a medical person and can only suggest people get proper medical info before any fasting. I've trained myself over nearly three decades to do it safely.)

Also, a media fast, i.e., no radio or newspapers (I haven't got television) is a great way to free the mind.

Best wishes, Elizabeth S., London, England, UK.

## Profits vs Patients' Rights

Dear Duncan: I write concerning my experiences as a result of my approaches to the bureaucracy, the legal fraternity and a multitude of politicians after experiencing a highly avoidable medical mistake. I believe it gives grist to the mill of a global conspiracy to defraud, exploit and kill off those who pay for these services, thereby making rich those who provide them.

My education into how my exploitation had been managed left me awed by my own naïvety. I accepted my surgeon's word that hysterectomy was necessary. I believed that, when someone is paid for performing and delivering a service, the client's or patient's welfare was paramount.

I was given (by my surgeon) a brochure on "Patients' Rights" and a brochure on "Hysterectomy". Both were NSW Department of Health publications. I went into hospital feeling informed and secure for my well-being.

Post-surgically, everything that could go wrong, did. HRT was pushed on me with promises that these nasties would cure my ills. No information was given in regard to adverse reactions or debilitation associated with this procedure and these medications. The positives of both the surgery and the subsequent HRT treatment were emphasised. No mention was made of risks and dangers...

It took me a long time to come to terms with the information that taxpayer-funded Department of Health brochures not only presented very biased misinformation but those "Rights" as presented did not actually exist.

I communicated with all the relevant bureaucratic and political authorities... Without exception the replies I have received negated me and my experiences...they obfuscated the issues I raised and belittled me...

I learnt of the *Rogers v. Whitaker* High Court decision (1992) in which the Court delivered a virtual blueprint for patients' rights—which, five years later, have still not been enacted in legislation...

Too many media outlets and journalists have been contacted in an endeavour to have these issues aired. Too many have declined, but always with wishy-washy excuses. Everyone is too fearful to take on vested interests whilst, at the same time, suppressing information the public has an inalienable right to know. Talk about censorship!

Real choice and informed consent in conventional health care is a myth. Since *Rogers v. Whitaker*, the *Medical Journal of Australia* has stated that doctors will need to decide *what* they tell patients...

The absence of infrastructure to redress violations of patients' rights epitomises the total disregard for the duty of care...

In the pursuit of profits and corporate power, the pharmaceutical industry is clearly not interested in patient care or public health. In collusion with others whose interests coincide (national medical associations, insurance, WHO, etc.) there is a concerted and fraudulent effort to exploit medical patients relentlessly.

I believe that the vast quantity of mostly nonsensical replies from politicians and bureaucrats I have received in the past six years amply prove all of the above. I would be delighted to make all of it public, signatures and all... (Anyone who would like copies of these documents, please send \$10 to cover copying/postage costs.)

Thank you once again for your very enlightening and evocative magazine.

Yours sincerely,

A. M. Vryenhoek, "Upson Downs", Nimbin Rd, Bishops Creek, NSW 2480, Australia.

## Vaccinations/Diabetes Link

Dear Duncan: I enjoyed listening to you on the Richard Boyden show on the "Heart of America Forum".

I was real interested when you spoke about the link of diabetes to child immunizations. My 13-years-old daughter was diagnosed with diabetes three years ago. The doctors told us that the blood tests told them that she contracted diabetes during a particular week. That week is when she got her immunizations for school.

Thanks, Jeff, Kansas City, Missouri, USA.

## Top-Secret Bases in Australia

Hi, Duncan: I was wondering if you or any readers might have any information on a top-secret scientific/industrial establishment in the Somersby area (near Gosford, about an hour's drive north from Sydney).

A week ago I met a gentleman at my computer course who told me he worked at Somersby. When I enquired what his occupation was, I was told he couldn't tell me what organisation he worked for, except to say that it was a private organisation. From there on it got more interesting.

He told me it involved nuclear physics and 'new energy sources', and that he was covered under the *National Secrecy Act* (which unfortunately I know little about). Supposedly he isn't able to use anything he has learnt from this organisation, if he ever leaves. (Incidentally, he told me he earns a six-figure salary, an inducement not to leave.) When I asked him if it involved our government, he told me it involved both our government and the United States Government.

I jokingly said to him, "So the things Brian Wilshire comes out with aren't so far-fetched after all?" He replied that fellow workers often come into work, saying that something else had been leaked onto the airwaves. He remarked how there were so many secret facilities in this country that people weren't aware of.

I know it all sounds like something out of the *X-Files*, but it does have me intrigued. If anyone has heard anything on the grapevine about this place, I would sure love to know. This man didn't leave me with the impression that he

was playing a joke on me. It would be interesting to find out what exactly is going on there. I didn't press him with too many questions, because sometimes I feel that the less you ask people like this, the more you are likely to get told.

I continue to enjoy the magazine, and especially like the *Global News*, *Twilight Zone* and the book reviews. Dr Greer's *UFO Manifesto* [NEXUS 4/02] was really intriguing, but I am a little doubtful the US Government will let him and the others get away with it. I guess we'll just have to wait and see.

Keep up the great work!

Anthony Z., Monterey, NSW, Australia.

[Dear Anthony: We hear rumours of secret bases all the time. As for Dr Greer, please note the update on CSETI's activities in *Twilight Zone* this issue. Ed.]

## Blatant Bias in Broadcasting

Dear Duncan: Quite some time ago Phillip Adams, on his "Late Night Live" program on Radio National (part of the ABC), rubbished NEXUS as a magazine and said that you had been seen in the company of one of the leaders of the Nazi Party here in Australia.

This attack shocked me because, if anything, my politics are leftist. The madness of the far right terrifies me—yet I had not seen anything in the magazine to indicate it held such a bias. On the other hand, I respected Phillip Adams' reporting.

Although confused, I continued to read NEXUS, aware of the shadow Phillip Adams had placed over you and your magazine. After 18 months I can find nothing to substantiate Adams' claims, and I would like your comments!

Yours faithfully, Lyn W., Alberton, Victoria, Australia.

[Dear Lyn: Mr Adams' claims are totally wrong and reflect both shoddy journalism and personal bias! NEXUS is not right-wing and it has no political agenda. Mr Adams has fallen under the spell of 'researchers' who work for the extreme-right-wing Australia-Israel Review, and seems more than happy to regurgitate their slanderous claims about NEXUS.

Mr Adams himself has never bothered to contact me regarding these silly allegations. And he calls himself a journalist?! Ed.]

## PROJECT CENSORED 1996

Project Censored is a media analysis and research program based out of Sonoma State University, California. Its stated goal is to "explore and publicise the extent of censorship in our society by locating stories about significant issues of which the public should be aware, but is not, for one reason or another."

Following are the 10 most censored stories for 1996, according to Project Censored:

### #1: Risking the World: Nuclear Proliferation in Space

While much press coverage was devoted to the failed Russian space probe that crashed into the South Pacific in November 1996—along with its payload of 200 grams of plutonium-238—virtually no attention has been paid to the 1997 launch of NASA's *Cassini* probe which will be carrying 72 pounds of the same deadly substance.

The plutonium in the *Cassini* probe will sit atop a Lockheed Martin-built Titan IV rocket, which has been involved in a series of mishaps including a 1993 explosion which destroyed a US\$1 billion spy satellite system and sent fragments falling into the Pacific Ocean.



### #2: Shell's Oil, Africa's Blood

In the wake of Nigeria's execution of nine environmental activists, including Nobel Prize winner and leader of the Movement for the Survival of Ogoni People (MOSOP), Ken Saro-Wiwa, evidence has indicated that the Shell oil company has fomented civil unrest in Nigeria, contributed to unfair trials and failed to use its leverage to prevent the unjustified executions.

The executed activists were involved in massive protests against Royal Dutch Shell

Group because of the environmental devastation it has caused—particularly in southern Nigeria's Ogoniland.

Since the executions, Shell has also managed to keep the United States media from informing the public of its actions.

### #3: Big Perks for the Wealthy Hidden in Minimum Wage Bill

On 20 August 1996, President Clinton signed into law the Small Business Job Protection Act of 1996, ostensibly geared to aid small business owners and their employees. The publicised intent of the bill was to raise the minimum wage from US\$4.25 to \$5.15 an hour.

However, according to John Judis, senior editor of the *New Republic*, the minimum wage bill included at least 10 other significant provisions aimed at neither small business owners nor their employees. Indeed, Judis charges, these unpublicised provisions may negate whatever good the bill may do.

### #4: Deforming Consent: The PR Industry's Secret War on Activists

Exposed are the multi-million-dollar clients of major public relations firms that are behind the creation of false non-profit organisations which target activists and proposed legislation that threaten big business. Most of these organisations focus on environmental, consumer and labour issues. The strategies of these powerful media manipulators include the defamation of activists and their ideas and the deception of American citizens.

Through the PR industry and the enormous financial resources of their corporate clients, these organisations mobilise private detectives, lawyers and undercover spies; influence editorial and news decisions; launch phony 'grassroots' campaigns; and use high-tech information systems to influence and manipulate public opinion and policy. With its array of sophisticated, persuasive weaponry, the PR industry can out-manoeuvre, overpower and outlast citizen reformers.

### #5: White-Collar Crime: Whitewash at the Department of Justice

While white-collar crime costs America 10 to 50 times more money than street

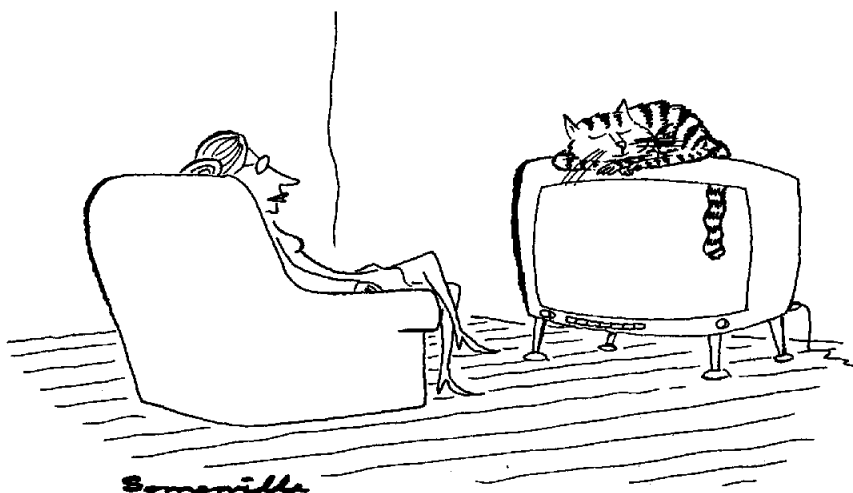

crime, the Department of Justice (DoJ) continues to show little interest in taking the problem seriously.

Based on the centralised records maintained by the DoJ, the data shows that when it comes to white-collar crime, the federal government almost never brings criminal charges against businesses. Of the more than 51,000 federal criminal indictments in 1994, only 250—less than one-half of one per cent—involved criminal violations of the nation's environmental, occupational health and safety, and consumer product-safety laws.

Given the huge number of corporations, the private admissions by business lawyers that their organisations often break the law, and a well-documented record of repeated violations, the minuscule number of federal criminal allegations hardly squares with the corporate view of business as the victim of a federal government run amok.

## #6: New Mega-Merged Banking Behemoths = Big Risk

1995 was a record year for bank mergers. Chase Manhattan and Chemical Bank combined to create the nation's largest bank, with US\$300 billion in assets; while on the west coast, the merger of First Interstate and Wells Fargo created a new giant with over US\$100 billion in assets.

The massive consolidation of the nation's banking resources has resulted in 71.5 per cent of US banking assets being controlled by the 100 largest banking organisations, representing less than one per cent of the total banks in the nation.

Studies have found that banks in concentrated markets tend to charge higher rates for certain types of loans, and tend to offer lower interest rates on certain types of deposits than do banks in less concentrated markets.

## #7: Cashing in on Poverty

Corporate America is in the poverty business and making huge profits from the destitute in the United States. Sixty million poor people without bank accounts or access to competitive-rate loans must instead use pawn shops, check-cashing outlets, rent-to-own stores, finance companies and high-interest mortgage lenders.

These businesses generate yearly revenues of US\$200 to \$300 billion and are increasingly owned or subsidised by Wall Street giants such as American Express, Bank America, Citibank, Ford, NationsBank and Western Union.

While affluent credit-card holders can pay as little as six to eight per cent annual interest, low-income people are paying as much as 240 per cent for a loan from a pawnbroker, 300 per cent for a finance company loan, and even an amazing 2,000 per cent for a fast 'payday' loan from a check-cashing outlet.

## #8: Big Brother Goes High-Tech

Information on individuals in the developed world can now be obtained by governments and corporations using new surveillance, identification and networking technologies. These new technologies are rapidly facilitating the mass and routine surveillance of large segments of the population—without the need for warrants and formal investigations.

In Britain, nearly all public areas are monitored by over 150,000 closed-circuit television cameras (CCTV). Equipped with a powerful zoom lens, each camera can read the wording on a cigarette packet at 100 yards. These cameras can track individuals wherever they go—even within buildings.

The FBI has developed miniaturised CCTV units that it can put into a "lamp, clock, radio, duffel bag, purse, picture frame, utility pole, coin telephone and other [objects]" and then control remotely

to "pan, tilt, zoom and focus".

Another type of surveillance camera currently in development boasts the equivalent of X-ray vision and can penetrate clothing to 'see' concealed weapons, plastic explosives or drugs. Known as the passive millimetre wave imager, it can also see through walls and detect activity.

Other emerging fields of surveillance include intelligent transportation systems (ITS) which track the movements of all people using public or private transport. Such systems are linked to ordinary bank accounts and can generate records that show a driver's name and address and the exact time and place where tolls have been charged.

Nine states in the US already use similar systems to track over 250,000 vehicles every day, and 12 more states will soon put their own systems on line.

## #9: US Troops Exposed to Depleted Uranium During Gulf War

Depleted uranium (DU) weapons were used for the first time in a war situation in the Persian Gulf in 1991 and were hailed as a new and incredibly effective weapon by the Department of Defense (DoD).

Although army training manuals were written in the 1980s to warn tank crews and commanders of the dangers associated with DU rounds, the Pentagon failed to warn Gulf War troops of the dangers.

The DoD did circulate a memo to Gulf War commanders that contained three key points: any vehicle or system struck by a DU penetrator can be assumed to be conta-

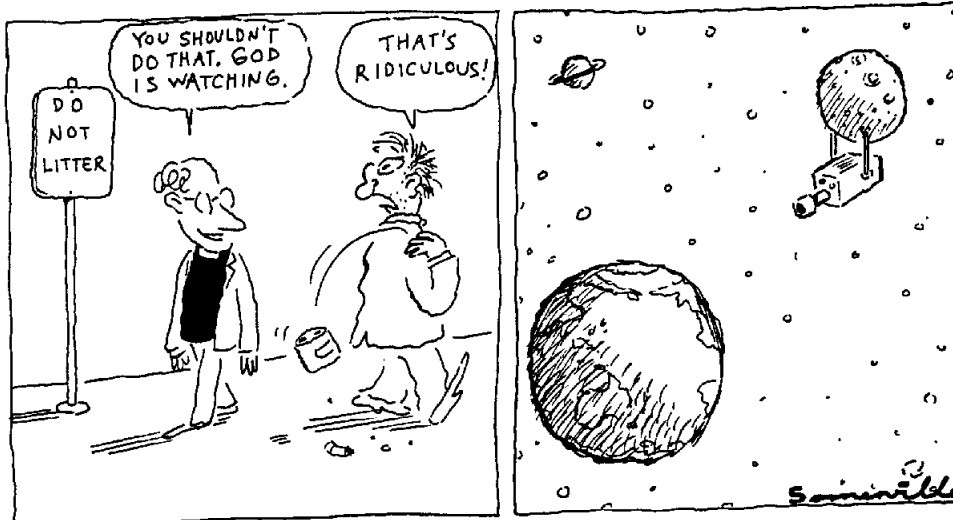

# ... GLOBAL NEWS ...

minated; personnel should avoid entering contaminated areas; and, if troops must enter contaminated areas, they should wear protective clothing.

Unfortunately, this memo was written on 7 March 1991, eight days after the firing of weapons ceased in the Persian Gulf.

## #10: World Facing Food Scarcity

The Japanese Ministry of Agriculture released projections in late December 1995 which show a doubling of world grain prices by 2010. The world prices for wheat and rice will exceed twice that of the base year of 1992.

Around the same time, World Watch published an article, "Facing Food Scarcity", which supports the Japanese Ministry of Agriculture claim. According to the World Agricultural Outlook Board, the world's stocks of rice, wheat, corn and other grains have fallen to their lowest levels in two decades.

The food shortage will become even more acute in light of the conclusions of the recent World Food Summit in November 1996. Convened by the FAO, the first summit in 22 years decided that poor countries will be responsible for feeding their own people, without the aid of wealthier nations.

(Source: *Project Censored Web Page*: <http://censored.sonoma.edu/projectcensored/Stories1996.html>)

## NON-POLLUTED PET FOOD

In NEXUS 4/01 we published an article entitled "Polluted Pet Food". To the readers who complained about the lack of alternatives, we suggest that they (and their pets) try the recipes below:

### Dog Food:

500 grams minced beef (not lean); 2 hard-boiled eggs; 4 cups boiled rice; 6 slices crumbed bread; 2 tsp calcium carbonate (crushed antacid tablets). Cook meat in covered pan until brown; keep fat. Mix well with remaining ingredients. If too dry, add water (not milk). Makes about 1.5kg. Keep in covered container in fridge.

### Dog Biscuits:

1-1½ cups of dog food recipe; 1 cup unprocessed bran; 1 cup uncooked oatmeal; ½ cup vegetable oil. Preheat oven to 120°C (248°F). Mash dog food in bowl. Mix in bran and oatmeal. Slowly add oil, mixing in more or less oil until mixture can be moulded into patties or bone shapes. Bake for 3½ hours. Cool; store in airtight tin. Will keep one month in fridge. Makes 16 to 20 biscuits.

### Cat Food:

1.25 kg cooked and minced chicken or beef liver; 2 cups cooked rice; 2 tbsp vegetable oil; 2 tsp calcium carbonate (crushed antacid tablets). Mix all in medium bowl. Will keep in fridge for five days, well covered; or three months frozen.

(Source: *Grassroots Magazine*, no. 116)

## VET THREATENED OVER PET FOOD DANGER CLAIM

A vet who claims that processed canned and dried pet food is ruining cats' and dogs' health is being threatened with deregistration if he doesn't shut up.

Dr Tom Lonsdale has been accused of professional misconduct by the Australian Veterinary Association (AVA) for voicing his concerns over increasing links between the AVA and the pet food industry.

Dr Lonsdale, a representative of the Raw Meaty Bone Lobby, claims that commercial pet food is helping cause an AIDS-like immune disorder in dogs and cats.

The lobby claims an "unholy alliance" between the veterinary profession and the lucrative pet food industry has developed, with vets promoting manufactured foods instead of natural foods in their surgeries.

Among the evidence cited by the lobby is the Pet PEP package prepared by the AVA for distribution to schools to promote "responsible" pet ownership.

The program was 18 per cent funded by the Petcare Information and Advisory Service, which is in turn funded by Uncle Ben's, the dominant company in the AUD\$700 million-a-year pet food industry.

If found guilty of misconduct, Dr Lonsdale could be struck off the veterinary register and banned from vet practice.

(Source: *The Sun Herald*, 16 March 1997)

## OZONE THERAPY UPDATE

Despite the best attempts of the gay lobby and the medical profession in Australia to kill off any credibility pertaining to ozone/oxygen therapy, reports continue to surface about people who have successfully treated AIDS and cancer with various forms of oxygenation.

As we continue to receive calls from people all around the world asking where the best treatment centre for this modality can be found, it was with some relief that we spotted the following recommendation in an oxygen therapy discussion group on the Internet. Ed.

### Comments on Oxygen Therapy

by Joseph Passero

I have attended every major ozone congress since 1993: San Francisco, USA, and Baden Baden, Germany, in 1993; Zürich, Switzerland, in 1994; Lille, France, and Nizhny Novgorod, Russia, in 1995; Baden Baden, Germany; Medica 96 in Düsseldorf, Germany, and Brussels, Belgium, in 1996; and, most recently, Havana, Cuba, in 1997.





# ... GLOBAL NEWS ...

I have also visited both private and public clinics and hospitals in all those countries.

I am the person responsible for starting the three ozone treatment centres that are on the oxytherapy list in the state of New York, USA. I still do work at two of them, performing approx. 50 to 70 major auto-haemotherapy treatments a week.

I was also responsible for the Medical Society for Ozone Therapy of Germany presenting the ozone therapy courses in English in 1993, 1994 and 1995.

The Ozone Research Center in Cuba is, in my opinion, the best that I have seen in the world for medical ozone treatment and ozone research, both medical and industrial. If I were looking for medical treatment, it is the first place I would consider. Contact details are as follows:

Ozone Research Center  
15 Ave & 230 St #1313, Sibony, Playa, or  
PO Box 6880, C. Havana, Cuba  
Phone: (537) 787 4141; Fax: (537) 21 0233  
E-mail: ozone@infomed.sld.cu

(Source: *Joseph Passero, 13 April 1997,*

*e-mail: jp@spacelab.net, via the Internet*

*Oxygen Therapy discussion group:*

*list@oxytherapy.com)*

## BIG BUSINESS TO RUN SMALL COUNTRIES?

A British think tank has proposed that multinational corporations "privatise" economically troubled countries. In the journal of London's Institute of Economic Affairs, Robert Whelan criticised foreign aid programs, arguing that "cash grants to Africa" only create "wealthy dictators".

Under Whelan's plan, the world's biggest companies would bid for leases to operate third world countries for up to 21 years, in exchange for an agreed-upon return on the earnings. Whelan says, "it might at least be worth a try", but Oxfam Africa's Kevin Watkins sniffs that, "if they knew their history, they would know that this has been tried before." It's called imperialism!

(Source: *Earth Island Journal, Winter 1996-97)*

## WOMEN UNITE TO SUE HRT DRUG MANUFACTURERS

In a landmark case in the UK, a group of 15 women who claim to have suffered serious side-effects through taking hormone replacement therapy (HRT) are attempting to sue the manufacturers of the drugs.

If the 15 women who have applied for

legal aid are successful, the class action is expected to lead to a flood of similar claims for damages.

HRT is prescribed to one in three British women in their 50s for menopausal symptoms (such as hot flushes and a reduction in bone strength) caused by a loss of oestrogen. But recent research has shown that in the first year of treatment, women taking HRT are four times as likely to suffer from deep vein thrombosis, leaving their legs permanently swollen, and life-threatening blood clots in the lungs.

Rosalie Houghton, a Hereford solicitor handling the cases of several claimants, says she has a coroner's certificate where HRT has been cited as a secondary cause of death in one case.

(Source: *The Sunday Telegraph [UK], 23 March 1997)*

## THE WRISTWATCH YOU WEAR IN YOUR WRIST

Conspiracy theorists will love this one! Scientists are testing a revolutionary watch which can be implanted beneath the skin of the wrist. The device, expected to be on sale within three years, would be inserted in a cheap and relatively painless procedure at an outpatients clinic. Because skin is partially transparent, the watch's time and date display would show through.

The invention, under development at computer company Interval Research in California, uses a liquid crystal display built into a thin film of plastic and sealed with a protective layer. It is controlled by a

microchip and powered by a small battery which is also implanted under the skin's surface. The battery is recharged by placing the wrist next to an inductive recharger.

The watch would be smart enough to know when to reset itself for time changes, but, if necessary, its setting could be altered via remote control.

Researchers believe the same technology could be used to create a range of electronic tags for criminals, and could be adapted to record medical information such as blood temperature and pressure.

Prototypes of the watch are reportedly already being tested. The mind boggles!

(Source: *Daily Mail [UK], 29 March 1997)*

## BIG BROTHER CAR CONTROL

The NRMA motorists' group is ready to launch a satellite-controlled road service: a Big Brother 'eye in the sky' that can unlock car doors by remote control and deliver assistance at the push of a button.

Called "StarTrack", when fitted to members' cars it will provide satellite tracking services using the Global Positioning System (GPS). With installation costs at A\$1,245, it will deliver a range of features, e.g., locating your stolen car and disabling its engine, or giving advance warning that your battery is almost flat. "StarTrack" also provides safety precautions such as a 'panic button', which, when pressed, alerts an operator that emergency help is needed.

(Source: *The Sydney Morning Herald, 2 May 1997)*

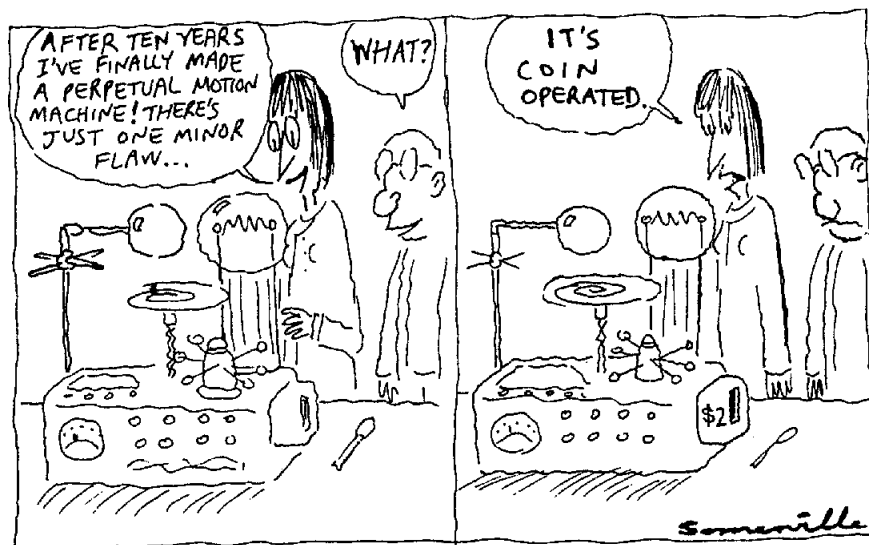







# Why Schools Don't Educate

**As teacher John Gatto pleads, the inherent problems with 'schooling' could be solved with methods that help children develop self-knowledge and self-reliance, and which encourage family involvement.**

## **A Speech by John Taylor Gatto**

235 W. 76th Street  
New York, NY 10023, USA

Originally published in *HOPE* magazine  
Vol. 1, No. 4, Sept/Oct 1996  
POB160, Naskeag Rd, Brooklin, ME 04616  
Telephone: +1 (207) 359 4651  
Fax: +1 (207) 359 8920

*When John Taylor Gatto was named New York City's Teacher of the Year (for the second year in a row) in 1990, his acceptance speech was not a quiet thank-you, but a loud-and-clear challenge to the conventional wisdom surrounding the role of education, family, individual and community today. Not just about New York City schools and children, his remarks address concerns that educators and parents feel, more or less deeply, no matter where they reside. The challenges we face in the education and engagement of our children are serious and complex, and they are not simply the responsibility of our schools. Yet schools can provide much of the context necessary for making our society and our world the kind of place in which we all want to live. So we take pleasure in publishing the impassioned remarks of one of the most vocal and articulate champions of educational reform.*

— Jon Wilson, Editor & Publisher, *HOPE* magazine

I accept this award on behalf of all the fine teachers I've known over the years who've struggled to make their transactions with children honourable ones: men and women who are never complacent, always questioning, always wrestling to define and re-define endlessly what the word "education" should mean. A "Teacher of the Year" is not the best teacher around—those people are too quiet to be easily uncovered—but a standard-bearer, symbolic of these private people who spend their lives gladly in the service of children. This is their award as well as mine.

We live in a time of great social crisis. Our children rank at the bottom of 19 industrial nations in reading, writing and arithmetic. The world's narcotic economy is based upon our own consumption of this commodity. If we didn't buy so many powdered dreams, the business would collapse—and schools are an important sales outlet. Our teenage suicide rate is the highest in the world—and suicidal kids are rich kids for the most part, not the poor. In Manhattan, 70 per cent of all new marriages last less than five years.

Our school crisis is a reflection of this greater social crisis. We seem to have lost our identity. Children and old people are penned up and locked away from the business of the world without precedent; nobody talks to them anymore. Without children and old people mixing in daily life, a community has no future and no past; only a continuous present. In fact, the name "community" hardly applies to the way we interact with each other. We live in networks, not communities, and everyone I know is lonely because of that. In some strange way, a school is a major actor in this tragedy; just as it is a major actor in the widening gulf among social classes.

Using school as a sorting mechanism, we appear to be on the way to creating a caste system, complete with untouchables who wander through subway trains begging, and who sleep on the streets. I've noticed a fascinating phenomenon in my 25 years of teaching—that schools and schooling are increasingly irrelevant to the great enterprises of the planet. No one believes any more that scientists are trained in science classes, or politicians in civics classes, or poets in English classes.

The truth is that schools don't really teach anything except how to obey orders. This is a great mystery to me because thousands of humane, caring people work in schools as teachers and aides and administrators, but the abstract logic of the institution overwhelms their individual contributions. Although teachers do care and do work very, very hard, the institution is psychopathic; it has no conscience. It rings a bell, and the young man in the middle of writing a poem must close his notebook and move to a different cell where he learns that man and monkeys derive from a common ancestor.

Our form of compulsory schooling is an invention of the State of Massachusetts around

1850. It was resisted—sometimes with guns—by an estimated 80 per cent of the Massachusetts population, the last outpost in Barnstable on Cape Cod not surrendering its children until the 1880s when the area was seized by militia and children marched to school under guard. Now here is a curious idea to ponder. Senator Ted Kennedy's office released a paper not too long ago claiming that, prior to compulsory education, the state literacy rate was 98 per cent, and after it, the figure never again reached above 91 per cent, where it stands in 1990. I hope that interests you.

**H**ere is another curiosity to think about. The home-schooling movement has quietly grown to a size where one and a half million young people are being educated entirely by their own parents. Last month the education press reported the amazing news that children schooled at home seem to be five or even ten years ahead of their formally trained peers in their ability to think.

I don't think we'll get rid of the schools anytime soon—certainly not in my lifetime—but if we're going to change what's rapidly becoming a disaster of ignorance, we need to realise that the school institution 'schools' very well, but it does not 'educate'. That's inherent in the design of the thing. It's not the fault of bad teachers or too little money spent: it's just impossible for education and schooling ever to be the same thing.

Schools were designed by Horace Mann, Barnas Sears and W. R. Harper of the University of Chicago, Thorndyke of Columbia Teachers College, and others, to be instruments of the scientific management of a mass population. Schools are intended to produce, through the application of formulae, formulaic human beings whose behaviour can be predicted and controlled.

To a very great extent, schools succeed in doing this. But our

society is disintegrating, and in such a society the only successful people are self-reliant, confident and individualistic—because the community life which protects the dependent and the weak is dead. The products of schooling are, as I've said, irrelevant. Well-schooled people are irrelevant. They can sell film and razor blades, push paper and talk on telephones, or sit mindlessly before a flickering computer terminal, but as human beings they are useless—useless to others and useless to themselves.

The daily misery around us is, I think, in large measure caused by the fact that—as Paul Goodman put it 30 years ago—we force children to "grow up absurd". Any reform in schooling has to deal with its absurdities.

It is absurd and anti-life to be part of a system that compels you to sit in confinement with people of exactly the same age and social class. That system effectively cuts you off from the immense diversity of life and the synergy of variety. It cuts you off from your own past and future, sealing you in a continuous present much the same way television does.

It is absurd and anti-life to be part of a system that compels you to listen to a stranger reading poetry when you want to learn to construct buildings, or to sit with a stranger discussing the construction of buildings when you want to read poetry.

It is absurd and anti-life to move from cell to cell at the sound of a gong for every day of your youth in an institution that allows you no privacy

and even follows you into the sanctuary of your home demanding that you do its "homework".

"How will they learn to read?" you ask, and my answer is, "Remember the lessons of Massachusetts!" When children are given whole lives, instead of age-graded ones in cellblocks, they learn to read, write and do arithmetic with ease if those things make sense in the life that unfolds around them.

But keep in mind that in the United States almost nobody who reads, writes or does arithmetic gets much respect. We are a land of talkers; we pay talkers the most and admire talkers the most, so our children talk constantly, following the public models of television and schoolteachers. It is very difficult to teach the 'basics' any more because they really aren't basic to the society we've made.

**T**wo institutions at present control our children's lives: television and schooling, in that order. Both of these reduce the real world of wisdom, fortitude, temperance and justice to a never-ending, non-stop abstraction.

In centuries past, the time of a child and adolescent would be occupied in real work, real charity, real adventures and the real search for mentors who might teach what one really wanted to learn. A great deal of time was spent in community pursuits, practising affection, meeting and studying every level of the community, learning how to make a home, and dozens of other tasks necessary to becoming a whole man or woman.

**Here is another curiosity to think about. The home-schooling movement has quietly grown to a size where one and a half million young people are being educated entirely by their own parents.**



When John Gatto's seventh-grade class threw bottles with notes into the waters off Coney Island, Wilma Amaro's bottle washed up on a New Jersey beach where it was picked up by the police chief. That led to a lunch invitation from the chief to Wilma and her mother, lessons about how pollution happens, and happy apologies from the students and the school.

New York Post photo by Robert Kalfus, 1990 ©NYP Holdings, Inc.

But here is the calculus of time the children I teach must deal with. Out of the 168 hours in each week, my children must sleep 56. That leaves them 112 hours a week out of which to fashion a self. My children watch 55 hours of television a week, according to recent reports. That leaves them 57 hours a week in which to grow up.

My children attend school 30 hours a week, use about eight hours getting ready, going and coming home, and spend an average of seven hours a week in homework—a total of 45 hours. During that time they are under constant surveillance, have no private time or private space, and are disciplined if they try to assert individuality in the use of time or space. That leaves 12 hours a week out of which to create a unique consciousness. Of course, my kids eat, too, and that takes some time—not much, because we've lost the tradition of family dining. If we allot three hours a week to evening meals we arrive at a net amount of private time for each child of nine hours.

It's not enough. It's not enough, is it? The richer the kid, of course, the less television he watches, but the rich kid's time is just as narrowly proscribed by a broader catalogue of commercial entertainments and his inevitable assignment to a series of private lessons in areas seldom of his choice.

And these things are, oddly enough, just a more cosmetic way to create dependent human beings, unable to fill their own hours, unable to initiate lines of meaning to give substance and pleasure to their existence. It's a national disease, this dependency and aimlessness, and I think schooling and television and lessons—the entire Chatauqua idea—have a lot to do with it.

Think of the things that are killing us as a nation: drugs, brainless competition, recreational sex, the pornography of violence, gambling, alcohol, and the worst pornography of all: lives devoted to buying things—accumulation as a philosophy. All are addictions of dependent personalities and that is what our brand of schooling must inevitably produce.

I want to tell you what the effect is on children of taking all their time—time they need to grow up—and forcing them to spend it on abstractions. No reform that doesn't attack these specific pathologies will be anything more than a façade.

1. The children I teach are indifferent to the adult world. This defies the experience of thousands of years. A close study of what big people were up to was always the most exciting occupation of youth, but nobody wants to grow up these days—and who can blame them? Toys are us.

2. The children I teach have almost no curiosity, and what little they do have is transitory. They cannot concentrate for very long, even on things they choose to do. Can you see a connection between the bells ringing again and again to change classes, and this phenomenon of evanescent attention?

3. The children I teach have a poor sense of the future, of how tomorrow is inextricably linked to today. They live in a continuous present: the exact moment they are in is the boundary of their consciousness.

4. The children I teach are ahistorical; they have no sense of how the past has predestined their own present, limiting their choices, shaping their values and lives.

5. The children I teach are cruel to each other: they lack com-

passion for misfortune, they laugh at weakness, they have contempt for people whose need for help shows too plainly.

6. The children I teach are uneasy with intimacy or candour. They cannot deal with genuine intimacy because of a lifelong habit of preserving a secret self inside an outer personality made up of artificial bits and pieces of behaviour borrowed from television or acquired to manipulate teachers. Because they are not who they represent themselves to be, the disguise wears thin in the presence of intimacy, so intimate relationships have to be avoided.

7. The children I teach are materialistic, following the lead of schoolteachers who materialistically 'grade' everything, and television mentors who offer everything in the world for sale.

8. The children I teach are dependent, passive and timid in the presence of new challenges. This timidity is frequently masked by surface bravado or by anger or aggressiveness, but underneath is a vacuum without fortitude.

I could name a few other conditions that school reform will have to tackle if our national decline is to be arrested, but by now you will have grasped my thesis, whether you agree with it or not. Either schools or television or both have caused these pathologies. It's a simple matter of arithmetic. Between schooling and television, all the time children have is eaten up. That's what has destroyed the American family: it no longer is a factor in the education of its own children.

What can be done? First, we need a ferocious national debate that doesn't quit, day after day, year after year—the kind of con-

tinuous emphasis that journalism finds boring. We need to scream and argue about this school thing until it is fixed or broken beyond repair, one or the other. If we can fix it, fine; if we cannot, then the success of home schooling shows a different road that has great promise. Pouring the money back into family education might kill two birds with one stone, repairing families as it repairs children.

Genuine reform is possible but it shouldn't cost anything. We need to rethink the fundamental premises of

schooling and decide what it is we want all children to learn and why. For 140 years this nation has tried to impose objectives from a lofty command centre made up of 'experts'—a central elite of social engineers. It hasn't worked. It won't work. It is a gross betrayal of the democratic promise that once made this nation a noble experiment.

The Russian attempt to control Eastern Europe has exploded before our eyes. Our own attempt to impose the same sort of social orthodoxy, using the schools as an instrument, is also coming apart at the seams, albeit more slowly and painfully. It doesn't work because its fundamental premises are mechanical, anti-human and hostile to family life. Lives can be controlled by machine education, but they will always fight back with weapons of social pathology: drugs, violence, self-destruction, indifference, and the symptoms I see in the children I teach.

It's high time we looked backward to regain an educational philosophy that works. One I like particularly well has been a favourite of the ruling classes of Europe for thousands of years. I think it works just as well for poor children as for rich ones. I use as much of it as I can manage in my own teaching—as

**Last month the education press reported the amazing news that children schooled at home seem to be five or even ten years ahead of their formally trained peers in their ability to think.**

much, that is, as I can get away with, given the present institution of compulsory schooling.

At the core of this elite system of education is the belief that self-knowledge is the only basis of true knowledge. Everywhere in this system, at every age, you will find arrangements that place the child alone in an unguided setting with a problem to solve. Sometimes the problem is fraught with great risks, such as the problem of galloping a horse or making it jump, but that, of course, is a problem successfully solved by thousands of elite children before the age of ten. Can you imagine anyone who had mastered such a challenge ever lacking confidence in his ability to do anything? Sometimes the problem is that of mastering solitude, as Thoreau did at Walden Pond, or Einstein did in the Swiss customs house.

One of my former students, Roland Legiardi-Laura, though both his parents were dead and he had no inheritance, took a bicycle across the United States, alone, when he was hardly out of boyhood. Is it any wonder that in manhood he made a film about Nicaragua, although he had no money and no prior experience with filmmaking, and that it was an international award-winner—even though his regular work was as a carpenter?

Right now we are taking from our children the time they need to develop self-knowledge. That has to stop. We have to invent school experiences that give a lot of that time back. We need to trust children from a very early age with independent study, perhaps arranged in school, but which takes place away from the institutional setting. We need to invent a curriculum where each kid has a chance to develop uniqueness and self-reliance.

A short time ago, I got \$70 and sent a twelve-year-old girl with her non-English-speaking mother on a bus down the New Jersey coast. She took the police chief of Sea Bright to lunch and apologised for polluting his beach with a discarded Gatorade bottle. In exchange for this public apology, I had arranged for the girl to have a one-day apprenticeship in small-town police procedures. A few days later, two more of my twelve-year-old kids travelled alone from Harlem to West 31st Street, where they began an apprenticeship with a newspaper editor. Next week, three of my kids will find themselves in the middle of the Jersey swamps at six in the morning, studying the mind of a trucking company president as he despatches eighteen-wheelers to Dallas, Chicago and Los Angeles.

Are these 'special' children in a 'special' program? They're just nice kids from central Harlem, bright and alert but so badly schooled when they came to me that most of them couldn't add or subtract with any fluency. And not a single one knew the population of New York City, or how far it is from New York to California.

Does that worry me? Of course. But I am confident that as they gain self-knowledge they'll also become self-teachers, and only self-teaching has any lasting value.

We've got to give the kids independent time right away because that is the key to self-knowledge, and we must reinvolve them

with the real world as fast as possible so that the independent time can be spent on something other than more abstractions. This is an emergency. It requires drastic action to correct. Our children are dying like flies in our schools. Good schooling or bad schooling, it's all the same: irrelevant.

**W**hat else does a restructured school system need? It needs to stop being a parasite on the working community. I think we need to make community service a required part of schooling. It is the quickest way to give young children real responsibility.

For five years I ran a guerrilla school program where I had every kid, rich and poor, smart and dippy, give 320 hours a year of hard community service. Dozens of those kids came back to me years later and told me that this one experience changed their

lives, taught them to see in new ways, to rethink goals and values. It happened when they were thirteen, in my Lab School program—only made possible because my rich school district was in chaos. When 'stability' returned, the Lab closed. It was too successful, at too small a cost, to be allowed to continue. We made the expensive, elite programs look bad.

There is no shortage of real problems in this city. Kids can be asked to help solve them in exchange for the respect and attention of the adult world. Good for kids, good for the rest of us.

Independent study, community service, adventures in experience, large doses of privacy and solitude, a thousand different apprenticeships—these are all powerful, cheap and effective ways to start a real reform of schooling. But no large-scale reform is ever going to repair our damaged children and our damaged society until we force the idea of 'school' open—to include family as the main engine of education.

The Swedes realised this in 1976 when they effectively abandoned the system of adopting unwanted children and instead spent national time and treasure on rein-

forcing the original family so that children born to Swedes were wanted. They reduced the number of unwanted Swedish children from 6,000 in 1976 to 15 in 1986. So it can be done. The Swedes just got tired of paying for the social wreckage caused by unwanted children, so they did something about it. We can, too.

**F**amily is the main engine of education. If we use schooling to break children away from parents—and make no mistake, that has been the central function of schools since John Cotton announced it as the purpose of the Bay Colony schools in 1650, and Horace Mann announced it as the purpose of Massachusetts schools in 1850—we're going to continue to have the horror show we have right now.

The curriculum of family is at the heart of any good life. We've gotten away from that curriculum; it's time to return to it. The way to sanity in education is for our schools to take the lead in releasing the stranglehold of institutions on family life; to pro-

**The Russian attempt to control Eastern Europe has exploded before our eyes. Our own attempt to impose the same sort of social orthodoxy, using the schools as an instrument, is also coming apart at the seams, albeit more slowly and painfully. It doesn't work because its fundamental premises are mechanical, anti-human and hostile to family life.**

Continued on page 81







# The PEGASUS File

**Former CIA/DIA  
deep-cover agent  
"Chip" Tatum  
reveals more  
disturbing details  
about high-level  
control of global  
drug-running and  
money-laundering  
operations.**

## Part 2

by David G. Guyatt ©1997

All correspondence c/- NEXUS Office  
55 Queens Road  
East Grinstead, W. Sussex RH19 1BG  
United Kingdom

Telephone/Fax: +44 (0)1702 217523  
E-mail: david.g7@ukonline.co.uk

**D**uring his 22 years as a deep-cover CIA and DIA operative, Gene "Chip" Tatum saw or participated in a remarkable series of covert operations. Foremost in his mind are the years 1986-92, when he operated for a group he called "Pegasus". This group operated on behalf of the US and other governments, undertaking tasks that ranged from narcotics smuggling to assassinations.

The name "Pegasus" was, in fact, a 'cover' designation used by Tatum to protect himself against possible prosecution. Earlier this year Tatum revealed the true structure of the group and explained why he felt the need to conceal it. Timing was all important. In a message to this writer, Tatum stated, "It has now been well past the five-year statute of limitations which could have come back and haunted me. That date was January 22, 1997. On January 21, 1992 I walked out of the Jupiter Island meeting to which I referred earlier."

Few individuals, even now, are aware of the significance of Jupiter Island. Located on the Atlantic coast of Florida, just a few miles north of Palm Beach, the island measures a mere half a mile wide and nine miles long. According to authors Webster Griffin Tarpley and Anton Chaitkin, island residents read like a "Who's Who" of the Anglo-American establishment. Many have close connections to the intelligence apparatus and not a few are, or have been, members of the notorious Skull and Bones Society, a secretive and influential Masonic lodge formed at Yale law school.<sup>1</sup> Interestingly, many of the early residents, including Averell Harriman and Prescott Bush—George Bush's father—were strong supporters of Adolf Hitler and his National Socialist Party prior to World War II. Even in recent years, George Bush continued to have unfinished work with Nazis domiciled in South America, Tatum says—especially while the world's eyes were turned towards Saddam Hussein and Iraq during *Desert Storm*. That, however, is another story.

Jupiter Island boasts hyper-security. All vehicles are tracked by sensors placed in the roads and every housekeeper, gardener or other non-resident is required by ordinance to be fingerprinted and registered. Residents themselves are carefully screened prior to being permitted to purchase real estate (many purchase by invitation, it is thought) and one of their primary duties as good residents is to perform active 'surveillance' to ensure the island remains secure.<sup>2</sup> It was here that Tatum met with and discussed sensitive projects with then Vice President and later President Bush, at the residence of his mother, Rose Bush.

### SECRET GOVERNMENT APPARATUS

The so-called Pegasus group's organisational structure, as provided by Tatum, demands recounting in detail. The various presidential orders, which led to the formation and operation of the covert activities in which Tatum and others participated, are significant for they constitute a secret government within a government. This is the power that hides behind the open face of democratic government. Some have called this power base "the Octopus". Activities include high-level narcotics trafficking, illegal transfers of ultra-high-tech weaponry, money laundering on a massive scale and an odd "hit" or "alignment" to keep wobbly-kneed individuals on the straight and narrow.

It was in 1981, according to Tatum, that "President Reagan signed National Security Decision Directive number 3 (NSDD-3) which authorised the Vice President to chair the Special Situation Group (SSG). The Special Situation Group was a division under the National Security Council (NSC). One entity formed to support the SSG was the Terrorist Incident Working Group (TIWG), established in April 1982 by authority of President Reagan in NSDD-30. This group consisted of representatives of the following:

Director of Central Intelligence, Department of Defense (DoD), FBI, NSC staff and others as required.<sup>3</sup>

Tatum explained that, "The purpose of TIWG is to provide SSG with direct operational support. TIWG then recommended to the President that a Terrorism Task Force be formed and chaired by the head of SSG (the Vice President). Reagan approved NSDD-138 in April 1984, which extended TIWG's arm and ability to form sub-groups. As a result of NSDD-138 was the formation of the Operations Sub-Group (OSG). The Sub-Group was a select NSC-DoD-CIA-FBI-foreign intelligence agency which operated so as to bypass the regular operations of intelligence/military/law-enforcement agencies. OSG was formed in February 1986."

Having revealed the framework of the authorising presidential directives necessary for the conduct of these covert operations, Tatum then detailed the nitty-gritty of the OSG: "I was an operative for OSG from April 1986 through January 1992. When I was operating under the authority of the OSG I would report directly to the OSG, not to the CIA or DIA. This 'secret government' apparatus, built by Bush from 1981 to 1986, was able to draw upon assets from the CIA, the DoD Special Operations units and the private sector. Using the private sector clause, Don Gregg, VP Bush's National Security Advisor, included a representative from British Intelligence and Israeli Intelligence. To date I have called this group 'Pegasus' in an attempt not to divulge its true identity until I was on safe ground. Although most of the missions performed by OSG-2 are classified, the existence of the organisation is now declassified."

Until Tatum forwarded these details, the existence of more than one OSG was unknown. In fact, Tatum has now revealed the existence of *three* OSGs. OSG-1 was headed by Ted Shackley and was "our anti-narcotics group".<sup>4</sup> OSG-2 was the anti-terrorism group and OSG-3 was "our 'alignment' group". Tatum was originally posted to OSG-2 which was commanded by Col. Oliver North. The third group, OSG-3, was commanded by Richard

Secord. Following the exposure of Oliver North's role in Contragate in 1987, North resigned as head of OSG-2 and his spot was taken over by Secord. Tatum moved up to command OSG-3 at the same time.

All three OSGs answered to those individuals who sat on the TIWG. General Colin Powell represented the Department of Defense; William Casey, the CIA; and Donald Gregg, the National Security Council. "FBI guys rotated in and out," Tatum says. "It was like they couldn't get anyone," he concludes. Representing British Intelligence was Sir Colin Figure. Formerly head of MI6, Sir Colin transferred in 1986 to become "Security

Coordinator", one of the top slots at the Cabinet office under the premiership of Margaret Thatcher. He retired in 1989. Amiram Nir represented Israeli interests until his assassination by an "Archer" team led by Tatum—at the request of high-level Israeli individuals—in 1988. Any of these six could "call a mission". In addition, George Bush could do likewise. Of significance, too, was the occasional representation on the TIWG of Lord Chalfont. The British lord was an adviser on "Mid-East affairs" between 1986 and 1990.

**Amiram Nir represented Israeli interests until his assassination by an "Archer" team led by Tatum—at the request of high-level Israeli individuals—in 1988.**

From the moment Chip Tatum was recruited to the OSG, he was posted to upstate New York where he established a number of cover businesses. One of these was Cedar Shores Estates, Inc.<sup>5</sup> This was his base of operations throughout the next six years.<sup>6</sup>

It may be no more than sheer coincidence that the name of the company is similar to Cedar Holdings, a British company that had a relationship to former British Conservative Party Treasurer, Lord (Alistair) McAlpine. Author Peter Jones, in an unpublished book, looked in some detail at the business activities of this Conservative Party "Grey Eminence" and leading Freemason.<sup>7</sup> Of no little interest was the author's detailed connections of numerous companies that he believed were involved in all manner of dark activities. Interestingly, these included a company called Leisure Circle that has a sinuous connection to Sir John Cuckney, one of the central figures of the Scott Inquiry into arms sales to Iraq.

Whilst these connections are admittedly tenuous, to say the least, it should be noted that Tatum's upstate New York operation was also involved in shipping the most sophisticated weapons across the border to Canada. Not least are the known connections between Oliver North's related gun-running operations that saw dirty money being laundered through the British Channel Islands and the London-based BCCI (Bank of Credit and Commerce International). Money laundering was one of the principal activities of Col. Oliver North.

#### THE "SUPERBILLS" STING

One operation of which Tatum has knowledge concerns the so-called "Superbills" or "Supernotes" sting. Years earlier, in the late '60s or early '70s, the CIA had secretly provided to the Shah of Iran a perfect set of printing plates that could

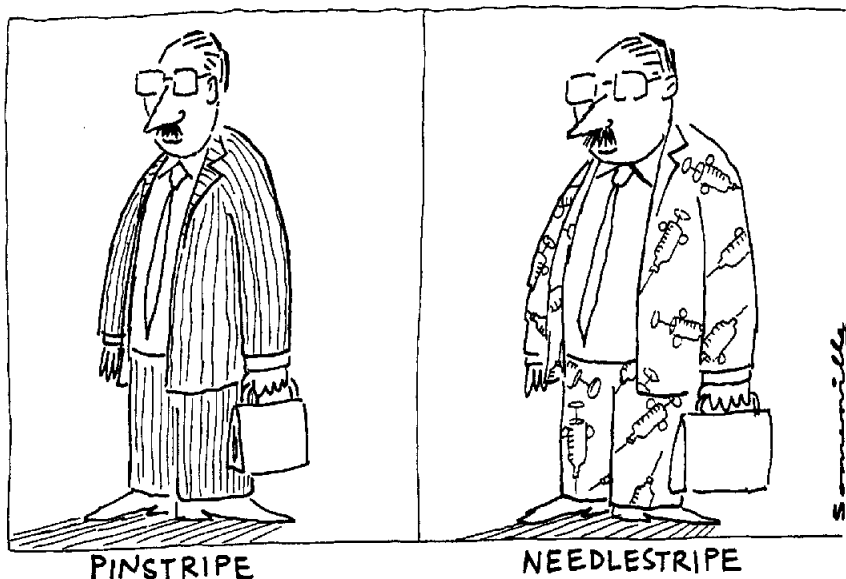

reproduce US\$100 bills without blemish. Also provided was an intaglio printing press. This special printing press ensures that the etched plate meets paper with tremendous force, creating the distinctive embossed feel of a genuine banknote. In addition, the Shah was also given the ink and banknote-quality paper, enabling him to produce perfect counterfeit US dollar banknotes. The Shah later fled Iran and left the plates and press behind in his confusion. The whole caboodle sat in the mint at Tehran, according to some experts.<sup>8</sup>

According to Tatum, a deal was arranged in the early to mid-'80s between VP George Bush, Panama's Manuel Noriega and the Iranian leadership. A sum of US\$8 billion deposited in the Banco

Nacional de Panama on behalf of Colombian cocaine king Pablo Escobar was "lent" to George Bush. Of this, US\$4 billion was shipped by plane to Iran where it was exchanged at a ratio of one good bill for two counterfeit bills. On the return trip, the 707 aircraft's cargo container carried two shrink-wrapped pallets containing \$4 billion each. The 707 arrived at Howard/Albrook Air Force Base in Panama where the pallets were offloaded under armed guard of the Panamanian military. The counterfeit notes were re-deposited into

Escobar's account at the Panama central bank. Under no circumstances could the counterfeit bills be permitted to leave the bank vault—for fear of devaluing the US currency with forged notes—and active steps would later be taken to ensure this.

The other half of Escobar's "good" money was placed into the hands of Nana DeBusia, the grandson of Guyana's first democratic leader. DeBusia was chosen by the CIA's William Casey to launder the massive sum into numerous bank accounts under the joint signatures of VP George Bush and Director Casey.

The next leg of the operation was to retrieve the \$4 billion exchanged with the Iranians for the Superbills. This was facilitated by the supply of military equipment, arms, ammunition and replacement parts for weapons systems. This part of the deal was arranged by Col. Oliver North on behalf of the CIA's William Casey.

The results of these complex manoeuvres were twofold. On the one hand the CIA acquired \$4 billion via the arms sales, for use in future black operations, without the need to rely on congressional oversight or authority. If later caught, Tatum says "...the CIA can report the source of funds as being from an arms transaction with Iran". Some of these funds were then used to support the Contras, whilst the rest disappeared down the ultra-black hole of the Company's covert finances.

Meanwhile, Nana DeBusia had begun laundering the remaining \$4 billion through various banks, including the Vatican Bank.<sup>9</sup> For his trouble, DeBusia was entitled to take a commission amounting to \$200 million. The remaining \$3.8 billion was then secreted in private, numbered accounts around the globe and controlled by George Bush and William Casey.

**...only one figure emerged unscathed: George Bush, who alone retained control of US\$3.8 billion in laundered funds.**

The operation was complete apart from some necessary mopping-up which occurred over the following years:

1) In 1989, Pablo Escobar was targeted by an intensive US-Colombian "War on Drugs" campaign. He fled into hiding, in fear of his life. Eventually, in 1993, he was tracked down and killed in a police shoot-out. A British TV documentary revealed that the "Cocaine King" was gunned down while attempting to escape and was probably unarmed. The campaign waged against Escobar ensured he could not withdraw the \$8 billion in Superbills. Following his death, the quantity and quality of cocaine shipments from Colombia immediately increased manifoldly, giving lie to the "War on Drugs".

2) Also during 1989, Panama's General Noriega was captured in the US invasion of Panama. Noriega was later convicted and placed in US federal prison under constant guard to ensure his silence.<sup>10</sup>

3) Penultimately, Nana DeBusia was indicted on 32 counts including bank fraud and thereby effectively silenced.<sup>11</sup>

4) Earlier, in 1987, DCI William Casey died of a brain tumour—just days before he would have been required to attend the Senate hearings into the Contragate affair.

According to Tatum, only one figure emerged unscathed: George Bush, who alone retained control of \$3.8 billion in laundered funds. Obviously, the CIA still retained control over the balance of their \$4 billion share of the 'sting' operation.

It is of considerable significance that this operation has been corroborated by another source whose credibility is not in question.<sup>12</sup> This individual was present in Tehran during many of these events, and was later posted to another sensitive location in this connection. Moreover, it has additionally been revealed that Banca Nazionale del Lavoro (BNL) was heavily involved in the Superbills sting. That BNL was an intrinsic part of Oliver North's so-called "Enterprise"—in reality, the OSGs of the Terrorist Incident Working Group—is beyond doubt.<sup>13</sup>

However, the question remains: What did George Bush intend



George Bush's favourite Ibero-American leader, Venezuelan President Carlos Andrés Pérez, meets with Bush in Washington. (Photo by Stuart Lewis)

to do with his 'black' \$3.8 billion? What was the ultimate purpose of the operation? Perhaps some of the money was to be used to grease palms and otherwise finance Bush's bid for the presidency following the completion of President Reagan's second term. Maybe it was used to finance other lucrative projects. Perhaps it

holders". In addition there are to be five departments: "Data Resources; Political Management; Economic Management; Military Management; Environmental Management".<sup>14</sup>

#### THE COMPLETE "BOSS HOGS" LIST

<b>EL SALVADOR</b> Duarte Balestaros Maty	<b>COUNTRY UNKNOWN</b> Santa Cruz Echeverri Bolinik
<b>HONDURAS</b> Suazo Cordoba Alvarez	<b>UNITED STATES</b> Casey Clair George Bush Singlab Kissinger Colby Haig Secord Gregg Weld Clairage Rodriguez Fernandez Peroot North
<b>MEXICO</b> Salinas brothers Albrego	
<b>US STATES</b> Arkansas: Clinton Young Louisiana: Edwards (Barry's buddy) Marcellas family Kentucky: Gov. in pocket	
<b>NICARAGUA</b> Colaro Borge Bermudez <b>Commanders:</b> Fernando Franklin Martin Chamoro Pastora Nora (a woman) Lacayo	<b>COLOMBIA</b> Ochoa Leder Navarro Richardo Duran Sarmiento
<b>ISRAEL</b> Rabin Kimchi Nir (P Ben or Guatamalian [ <i>sic.</i> ] arms dealer for Israel) Harrari	<b>SAUDI ARABIA</b> Fahd Prince B [Tatum believes this to be Prince Bandar] <b>IRAN</b> Gorba <b>PANAMA</b> Noriega & his brother Harrari

But it is in the realm of narcotics trafficking that Tatum is most vociferous. Part 1 of this article recounted the names of high-level US individuals, given to Tatum by Barry Adler Seal before he was killed in 1986. Seal called this the "Boss Hogs" List and it included senior individuals in 11 different countries who, Seal claimed, controlled the global narcotics network. The complete list is reprinted verbatim (including spelling mistakes), and in the manner in which it was written by Tatum on the reverse of a flight log:<sup>15</sup>

#### FULL CIRCLE

In a very real sense, Chip Tatum's story has now gone full circle. In March 1996, Tatum wrote to former Director of Central Intelligence, William Colby. Readers will recall that it was Colby who originally recruited Tatum into the CIA in 1971 and set him on his career as a covert intelligence operator. Since that time, Tatum developed a fondness for the super-spook, and Colby, in turn, played the role of mentor. In his letter, Tatum asked Colby to write a foreword for his book, *Operation Red Rock*, which he had completed just two months earlier. But there was another purpose in writing to the former DCI.

Four years earlier, when Tatum resigned his OSG command, he had volunteered to plead guilty on a felony charge in order to discredit himself. This was part of Tatum's strategy of survival, as he was aware that one didn't resign this particular team and remain alive for long. The fact that he had collected a body of evidence (including video and audio tapes and other related documentation) as 'life insurance', gave muscle to his negotiation. At that time he had not

was to be used to inject financial muscle into another, grander scheme, of which Tatum has recently spoken, involving George Bush's "scope and mission" paper for a New World Order.

A copy of the "scoping" paper supplied to Tatum by George Bush outlines the formation of a Corporation whose purpose is to "...provide a central network of information, analysts and strategists on an international basis in pursuit of world order and economic stability". The "scope" of the Corporation involves four features:

- 1) Centralisation of informational services;
- 2) Analysis of data by region-specific analysts;
- 3) Provide recommendations based upon analysts' reports by international experts;
- 4) Provide international master plan for world growth and economic stability.

The Corporation is to be privately owned with a board of directors "consisting of twelve members, elected annually by the share-

planned to reveal any of the details that he has now provided. In the event, his offer was taken up and he served a prison sentence of just over one year. That is where matters should have ended.

However, having served his sentence—thus complying with his part of the agreement—both Tatum and his wife, Nancy, were subsequently arrested and charged with another misdemeanour. Tatum got angry. His letter to Colby stated: "I have always kept my word with you. I told you that I would discredit myself. I don't need your help to accomplish this. But to charge Nancy with a crime, and expect me to allow this, is beyond my comprehension." He angrily continued: "I know that North and Rodriguez are the fuel for this, but haven't you warned them that I wouldn't sit still for this?" He then added: "I do not blame you for this; I am disappointed that you have allowed the 'Pond Scum' to control you!"

There then followed a warning: "The second book that I have already started will contain my movements from 1980 through

today. I will not only write about the missions but about the NWO [New World Order] timetable and planned events including a chronology." Ominously he added: "And I will name names. You must detach yourself from these people!"

Tatum then continued by outlining how he would enter evidence for his forthcoming trial and warning that if disallowed for reasons of classification, then "a Special Prosecutor will be required to investigate the information, and the videotape tells no lies." He added: "I also had stills and an audio clip of a meeting added to the video. Out of respect for you I have kept your name out to this point, but if you don't separate yourself from these terrorists I will have no choice but to reveal your involvement also. Either way, the group will be exposed—by the media or by the investigating committee. Either way, they're out of gas!" Tatum closed the letter by saying: "Mr Colby—you've done too much for your country to be disgraced in the manner that these men will be."

Less than two months later, the former DCI was reported missing. By Monday 6 May 1996, Colby's body was found. It was later reported that Colby died following a "canoeing" accident on the Wicomico River, Maryland. Tatum and many others (including this writer) doubt this. Throughout his life, Colby had an all-

abiding fear of water. It would have been entirely out of character for him to step voluntarily into a boat, let alone a canoe.

Despite this, Colby's death officially remains an accident. This has come as no special surprise to Tatum, who recently stated to this writer: "I knew the OSG were bulletproof when one of our targets, a 25-year-old, was reported to have died of a heart attack. His name was Al-Jarrah." That, however, is another story.

## POSTSCRIPT

At 3 pm on Friday 4 April 1997—shortly after publication of Part 1 of this article—Chip Tatum was roused from a mid-afternoon snooze and told to report to the warden of his prison. He was informed that he was being released—less than midway through his 27-month sentence—with immediate effect, following an appellate court decision that found his conviction by Judge Adams to be illegal.

The Tatums are now freely enjoying together the sunshine and cajun cooking of Florida, as Chip turns his attention to beginning a new career—his first real job-hunting in 26 years. "Spy stuff" will not form part of his job-search efforts. Meanwhile, he has written and published his *Chronicles* that detail many of his allegations.<sup>15</sup>

## Endnotes

1. Tarpley, Webster Griffin and Chaitkin, Anton, *George Bush: The Unauthorized Biography*, Executive Intelligence Review, Washington, DC, USA, 1992.  
2. *ibid.*  
3. Additional standing members were the Department of State and the Federal Emergency Management Agency (FEMA). NSDD-30 was classified "Secret". Now partly declassified, the redacted sections nominated NSC staffer Col. Oliver North responsibility for "antiterrorist operations". This included so-called "active measures" to "deter or pre-empt terrorist attack", and established the administrative framework for "CIA projects aimed at killing leaders of radical Islamic organizations". As such, it was an illegal presidential directive. My thanks to Steve Aftergood of the Federation of American Scientists, Washington, DC, for providing research extracts of these and other NSDDs drawn from Christopher Simpson's book, *National Security Directives of the Reagan and Bush Administrations* (Westview Press, San Francisco).  
4. Shackley's involvement in the narcotics industry is legion. Not least, Col Bo Gritz—the most highly decorated Special Forces officer in history—has spoken of his encounter with the Burmese warlord Khun Sa. Housed in the centre of the "Golden Triangle", Khun Sa is one of the world's leading exporters of raw opium. In an interview captured on camera, the warlord stated that his primary contact in the heroin business was the CIA's very own Ted Shackley. Shackley worked closely with Mafia chief Santos Trafficante, according to Khun Sa.  
5. Tatum has stated that it was routine for all the OSG operatives to establish their own businesses as "covers". Funding was provided as a line of credit with the Key Bank of Central New York, Watertown, New York state, by Republican Harry Hyde. The company was formed by attorney Ben Whittaker. Legal representation was through O'Hara and Crough in Syracuse, NY. Tatum also operated through a number of other similar "fronts". These included Progressive Structures, Inc., Irving

Place Capital & Development, and American National Home Builders.  
6. Tatum has provided me with a number of documents of this proprietary company, including details of incorporation, board minutes, bank statements, legal billings and copies of cashed cheques. In addition he has also provided documents relating to other front companies he was involved with.  
7. Jones, Peter, *The Obedience of Australia*, privately published, 1995. This book covers in considerable detail Masonic business connections that are shadowy to say the least.  
8. For additional details see the article by Fredric Dannen and Ira Silverman, published in the *New Yorker*, 23 October 1995.  
9. Tatum says DeBusia laundered this sum through banks in London. Coincidences abound in this story and they may be no more than coincidences. However, I think it is worth citing Gerald James, former Chairman of Astra Plc and one of the principal figures in the Scott affair and arms sales to Iraq. In his book, *In the Public Interest* (Warner Books, 1996), Gerald James has reproduced an internal company memorandum referring to the massive British-Saudi Al Yamamah arms deal in which a sum of US\$4 billion is mentioned in connection with a bribe to Saudi Prince Bandar, a nephew of King Fahd. The memorandum stated: "This 4 bil US was mentioned in connection with M. Thatcher's son." Interestingly, the sum of \$3.8 billion is mentioned in the Kerry Report that looked into the Iran-Contra affair.  
10. One of the principal prosecution witnesses against General Noriega was Gabriel Tabóada. Arguably, without Tabóada's testimony (he was regarded as the "star witness") the prosecution case against Noriega may well have failed. Tatum has provided this writer with a number of private letters and other documents written by Tobóada. These clearly show that Tobóada was "coached" by the prosecution in what to say and, more significantly, what *not* to say. Tobóada's correspondence makes it clear he was aware that the prosecution case against Noriega was severely flawed by perjury—a fact known to the prosecution team. Today,

Tobóada lives in fear of his life—a state of affairs that the US Department of Justice dismisses out of hand.  
11. Following the intervention of the CIA, DeBusia was acquitted on all counts. Effectively discredited, he will continue to maintain silence.  
12. Private communication with this writer.  
13. See Alan Friedman's *The Spider's Web* (Faber & Faber, 1993) for a more detailed role of BNL in the Contragate affair. I have been reliably informed that significant portions of Friedman's original manuscript were excised by a wary publisher.  
14. It is impossible to judge the veracity of this document for a number of reasons. Principally, the name of the Corporation is not stated and the document itself is typed on blank A4 paper running to three pages. Readers must make of it what they will.  
15. A copy of the original flight log is in this writer's possession.  
16. *The Tatum Chronicles*, an A4-sized, softbound manuscript, can be ordered by credit card by telephoning (352) 330 1650 (in USA) or +1 (352) 330 1652 (outside USA). It is priced at USD\$19.95 plus postage and handling. The *Chronicles* contain reproductions of Chip's flight logs with notes (front and back), along with an eye-opening commentary.

## About the Author:

Born in England, David Guyatt is a freelance investigative journalist whose former career in stockbroking and banking gave him the background that inspired his research into the shady world of international weapons financing, drug-running and money laundering. His current research interests are focused on military/intelligence mind-control programs and non-lethal weapons systems, as well as the hidden influence of elitist groups around the globe.





# ***A Bitter Pill to Swallow***

## **The Oral Contraceptives Betrayal**

***Women have achieved greater sexual freedom at terrible cost to their health and well-being.***

***Contrary to the advice of drug companies and doctors, the Pill has grave side-effects, including cancer, heart disease and stroke.***

***Part 1***

**by Sherrill Sellman ©1997**

Light Unlimited Productions  
Locked Bag 8000-MDC  
Kew, Victoria 3101, Australia  
Telephone: +61 (0)3 9249 9591  
Fax: +61(0)3 9855 9991  
E-mail: golight@netspace.net.au

**A** revolution was about to begin when the birth control Pill arrived on the scene in 1960. It heralded an era that would emancipate fertile women from the burden of unwanted pregnancies, thus opening the door to greater equality and freedom. For the past 37 years, about 200 million women around the world have chosen the Pill as their preferred method of contraception. This 'medical miracle' has enlisted almost 90 per cent of Western women of reproductive age on some kind of contraceptive at some time in their lives.

The choices of the steroid hormone contraceptive have now expanded to include the combined Pill and the low-dose Pill, made with oestrogen and synthetic progesterone, i.e., progestin, or the mini-Pill, implant and injection, made only with progestin.

The Pill has been proclaimed as one of the most studied drugs in history. After three decades of experimentation (unfortunately, on unsuspecting Pill-users) we are told that safe dosages are, at last, finally known. However, as the thin veneer of advertising hype, pharmaceutical cover-ups and sanitised clinical trials is peeled away, another picture emerges revealing the devastating consequences to women's health and well-being from the use of steroid hormones found in the Pill, as well as in hormone replacement therapy (HRT) which uses the same steroid drugs.

Far from being safe and risk-free, it is now being recognised that these steroid hormones are actually dangerous and potentially life-threatening drugs that cause grave harm to women. The sexual freedom that women have fought so hard to attain has been won at a terrible price. In fact, with hindsight, it will very likely be recorded in history that the widespread prescribing of synthetic hormones to women was the biggest medical bungle in history. Most women taking the contraceptive pill (or, for that matter, HRT) have very little idea about the hormones they are putting into their bodies; nor are they knowledgeable about the potential side-effects. A soaring incidence of breast and cervical cancers as well as strokes, cardiovascular disease, blood clots, impaired immunity, infertility and major nutritional imbalances are only some of the conditions undeniably linked to these hormones.

### **THE PILL'S HIDDEN AGENDA**

In the 1950s, the spectre of a world doomed by overpopulation was alarming scientists and governments in the industrialised West. Thus began a frantic rush to control populations. This coincided with the discovery of a relatively inexpensive process for making synthetic oestrogen and progesterone that could be used as contraceptives, known as the combined Pill.

Even though as early as 1932 it was known that oestrogen and progestin could cause cancer of the breast, womb, ovaries and pituitary glands in animal experiments, the Pill was believed to be an effective solution to the overpopulation crisis. Plans for manufacturing sex hormones were well underway and the required clinical trials were initiated.

Nobel laureate Frederick Robbins expressed the prevailing attitude of the time when he addressed a meeting of the American Association of Medical Colleges, stating that "the dangers of the overpopulation are so great that we may have to use certain techniques of conception control that may entail considerable risk to the individual woman".

And considerable risks they did contain. Envoid, the first oral contraceptive, was given a clean bill of health by the US Food & Drug Administration (FDA) in 1960 on the basis of clinical studies which involved only 132 Puerto Rican women who had taken the Pill for a year or longer. Five women died during the study, but no effort was made to deter-

mine the cause of their deaths. Not surprisingly, the initial trials were flawed and inadequate.<sup>1</sup> The fact that there was no evidence that the product was safe did not seem to be a cause of great concern to the researchers. In spite of what should have been a serious warning, the Pill was promoted with all the enthusiasm that the pharmaceutical companies could muster.

Although it was known early on that the Pill caused blood clots, it wasn't until the mid-1970s that the death toll for young women from heart attacks and strokes began to get public attention. The prophetic warnings from some doctors—that the widespread rise in use of oral contraceptives would create health hazards on a scale previously unknown in medicine—were coming true.

Dr Ellen Grant, an early researcher into the harmful effects of the Pill and author of *The Bitter Pill* and *Sexual Chemistry*, said way back in the 1960s that she was shocked when synthetic hormones were not withdrawn from the market due to their then known, serious side-effects. Statistics have confirmed that the early Pill users were up to 11 times more likely to have thromboembolisms.<sup>2</sup>

In effect, there are presently about 60 million women 'trailing' the Pill around the world. It is evident that the early reassurances by governments and pharmaceutical companies were lies. A recent study for the Inspector General's Office of the US Department of Health and Human Services disclosed that more than 70 per cent of oral contraceptive advertising to doctors is "misleading or unbalanced"—making contraceptives the most "deceptively advertised" category of prescription drug, with antibiotics in second place.<sup>3</sup>

While the Pill in its many forms has been accepted successfully into the lifestyles of millions of women, the fact remains that the long-term effects from artificially altering a woman's hormonal and reproductive life bode ill for the health not only of the women themselves but also of future generations. Dr David Clark, a neurologist with the University of Kentucky School of Medicine, expressed the truth when he said that, "The Pill allows experiments on the general population that would never be allowed as a planned experiment."<sup>4</sup> How generous of women to be donating their bodies to medical science, even if no informed consent has ever been given.

By 1975, the devastating effects from young Pill-takers dying from blood clots and heart attacks caused public outrage. The ensuing pressure from consumer groups convinced the FDA Commissioner to propose that oral contraceptives be accompanied by package inserts: full-length comprehensive warnings about possible side-effects of the recommended dosage. It was expected that there would be opposition from the manufacturers. What was not anticipated, however, were the heated attacks from the American Medical Association and the American College of Obstetricians and Gynecologists. It seemed that if the medical profession, not wanting to trigger undue alarm among patients, wasn't fully informing women of the risks, then nothing else should either.

With almost four decades of knowledge of the many side-effects of the Pill, there are still few doctors who adequately warn their patients of the many risks and potentially serious problems associated with taking the Pill. In 1995 Professor John Guillebaud, a noted English expert on family planning, wrote,

"Although not risk-free, the Pill's benefits far outweigh its risks. Another way of saying this is that the Pill is safe—but some women are dangerous."<sup>5</sup>

Such double-speak lulls doctors and women into a false sense of security, assuring them that the newer generations of oral contraceptives are now perfectly safe. Unfortunately, nothing could be further from the truth.

## HOW THE PILL WORKS

Hormones are very powerful substances. Begin tampering with Nature's finely tuned messengers of life's processes and you are asking for trouble. This is especially true for women. A woman's psyche is intimately connected to her monthly flow of hormones.

Hormones not only direct and determine physiological processes but also influence emotional and psychological states. Besides controlling sexual development and function, hormones also help to control growth and muscle building, and regulate the digestive system, blood sugar levels, blood pressure and fluid balance.

Hormones also hold the key to subjective feelings and changes in blood chemistry associated with stress. Hormonal imbalances not only create myriad health problems and diseases but can also undermine self-esteem, the sense of well-being, emotional balance and mental acuity.

The two main hormones in a woman's body are oestrogen and progesterone. Nature has choreographed

these two hormones to work together with exquisite timing and balance. Oestrogen, which is produced in the first half of a cycle, is responsible for the sexual development of females: the growth of breasts, the development of the reproductive system and the shape of the female body. It also stimulates the growth of cells preparing the endometrial lining for fertilisation each month. The target organs of the breast, uterus and ovaries as well as the skin are particularly sensitive to oestrogen.

Progesterone halts oestrogen's effect of rapid cell growth. It also develops the proliferative lining of the uterus, ensuring the implantation of a fertilised egg (it is the progestation hormone). Progesterone is known as the mother of all hormones since oestrogen (which is really made up of three kinds: oestradiol, oestrone and oestriol) and testosterone are all made from it. Progesterone is not only a sex hormone; it is also intricately involved in maintaining many other vital physiological functions.

In 1836, a surgeon named Cooper published his observation that the stage of the menstrual cycle influenced the speed of growth and division of breast cancer cells. They proliferated more rapidly in the early part of the cycle when ovaries are secreting oestrogen. By 1896 the *Lancet* reported the experiments of Beatson who removed the ovaries of women with breast cancer, causing their advanced disease to go into remission. At the same time it was discovered that the secretions of the yellow cyst in the ovary prevented the release of any more eggs once a pregnancy had started. This gave rise to the idea that oestrogen and progesterone could be used as a contraceptive.<sup>6</sup>

By 1932 it was known that oestrogens and progestins could cause cancer of the breast, womb, ovaries and pituitary gland in experimental animals, but the plans for manufacturing sex hormones were well underway.

The body's own internal hormones are endogenous, while those

**"The Pill allows experiments on the general population that would never be allowed as a planned experiment."**

**— Dr David Clark, neurologist,  
University of Kentucky School of Medicine**

from outside, eaten in food or prescribed as medication, are exogenous. Most oestrogens, whether natural and endogenous or synthetic and exogenous, like Premarin, still act exactly like oestrogens, have the same action and attach themselves to oestrogen receptors. All exogenous hormones tend to cause biochemical stress.<sup>7</sup>

When a woman is pregnant, levels of oestrogen and progesterone rise and further egg production is stopped. The hormones levels continue to rise during pregnancy, signalling the brain to stop secreting its egg-stimulating hormones. The contraceptive Pill hormones mimic this effect and continually dupe the brain into thinking that pregnancy has occurred, thus suppressing ovulation.

Present-day oral contraceptives are made up of varying doses of oestrogen-progestin formulations (the combination Pill) or progestin-only products (the mini-Pill or implants such as Depo-Provera).

The Pill literally stops menstruation. Bleeding only occurs each month because the synthetic hormones are not taken for seven days of the cycle. The bleeding that occurs would be more accurately termed "withdrawal bleeding", not menstruation. In fact, there is nothing natural about taking the Pill. The action of the Pill actually 'castrates' a woman by stopping her natural reproductive cycle, sometimes permanently damaging her ovaries and even causing infertility. To varying degrees the various formulations of the Pill signal the brain to suppress ovulation.<sup>8</sup>

In addition, all formulations of the Pill cause alterations to cervical mucus. The cervical mucus may become thicker and hence make it more difficult for sperm to move through the neck of the cervix.<sup>9</sup> This presents obvious difficulties when a woman decides to stop taking the Pill in the hope of becoming pregnant.

Both the progestin-only and oestrogen-progesterone formulations act to cause alterations to the lining of the womb, converting the proliferative nature of the endometrium—which is naturally designed to accept and sustain a fertilised ovum—to a secretory endometrium, which is a thin, devascularising lining, physiologically unresponsive to receiving and sustaining a zygote.<sup>10</sup>

The Pill also causes changes to the movement of the Fallopian tubes which may alter the time taken for the passage of the ovum and hence reduce the possibility of the ova being fertilised.<sup>11</sup>

Clearly, when you tamper with a woman's hormones you are tampering with her most sensitive physiological and psychological processes. By interfering with these vital processes, many profound changes are initiated in a woman's body.

## THE PILL AND BREAST CANCER

For the best part of two centuries we have known that sex hormones cause cancer in hormone-dependent tissues, such as in the breast. In 1940, around the time that pharmaceutical oestrogenic chemicals were first appearing on the market, an American woman's lifetime risk of breast cancer was 1 in 20. In 1995 the risk is now 1 in 8. In Australia, it is presently 1 in 14.

"Every study shows an increase now," confirms Carol Ann Rinzler, author of the authoritative book, *Estrogens and Breast Cancer*. Rinzler is especially worried about the youngest users who may take the Pill for four years or longer prior to the birth of their first child. These young women, she explains, have the highest risk of developing cancer from using the Pill, and the highest risk of acquiring sexually transmitted diseases. Teenagers are particularly vulnerable to the potent artificial steroid drugs contained in the Pill. According to a report in the November 1995 *Natural Fertility Management* newsletter, the Pill causes 150 chemical changes in a young woman's body.

The prevailing myth that the Pill is a safe and natural way to correct hormonal imbalances has led to its widespread use in correcting teenagers' menstrual cycles or alleviating painful periods. Puberty has now been medicalised. Even though Nature often requires several years to help balance out a teenager's menstrual cycle, girls as young as 13 who complain of irregularities will all too often be recommended or prescribed the Pill, supposedly to help 'regulate' their periods. Such common practices are both irresponsible and highly dangerous.

Professor Vincent, formerly chief hydrologist at the Department of Hydrology at Paris University, pioneered what has become known as the Bio-electronic Vincent Method of assessing healthy blood and tissue parameters. By conducting tests that measured such indicators as pH, resistance and redox potential in blood, urine and saliva, he was able to determine a subject's general health. When he directed his testing methods to assess the health of women using the Pill, his results were quite shocking. Women on the Pill showed a definite shift of parameters towards a malignant pattern within just a few months of starting to use it!

By the mid-1970s a new test, allowing doctors to identify oestrogen-dependent tumours, established that approximately one-third of breast cancers contain cell chains that hook up with oestrogen molecules. Such tumours are called "oestrogen receptor positive", or "ER+."<sup>12</sup> Very simply, they grow when exposed to oestrogen and shrink when their source of oestrogen is withdrawn. This new technology has allowed epidemiological

### The Pill is contraindicated for women with a personal history or family history of:

- Angina pectoris
- Blood clots
- Breast nodules or fibrocystic disease of the breast
- Cancer, known or suspected, of the breast or reproductive organs
- Cigarette smoking
- Depression
- Diabetes
- Epilepsy
- Fibroid tumours of the uterus
- Gall bladder disease or gallstones
- Heart or kidney disease
- High blood pressure
- High cholesterol or triglycerides
- Liver tumours
- Migraines or recurrent headache
- Multiple sclerosis
- Obesity
- Pregnancy-triggered diseases, e.g., jaundice, herpes, chloasma
- Pregnancy, known or suspected
- Recurrent or active hepatitis
- Unusual vaginal bleeding
- Varicose veins (large, swollen, or tender)
- Very irregular menstrual cycles or late menarche
- Women who are currently breast-feeding
- Women over 35, especially if they smoke or suffer from poor circulation

(Source: *Natural Fertility*, by Francesca Naish)

researchers to examine which kinds of breast cancer tumours, ER+ or not ER+, are increasing at a faster rate.

In 1990 a study based on information from the Kaiser Permanente tumour registry in the US revealed that from 1974 to 1985 the nationwide incidence of ER+ breast tumours rose 131 per cent—about five times faster than the incidence of tumours without oestrogen receptors.<sup>13</sup>

In 1995, after publication of a study on trends in cancer incidence and mortality in the United States, Dr Joseph Fraumeni Jr, an epidemiologist at the National Cancer Institute, told the *New York Times* that the rise in tumours that are stimulated by oestrogen (but not in those that do *not* respond to oestrogen) "suggests that some hormonal factor may be involved". Fraumeni's list of possible influences include contraceptives and menopausal hormones, exposure to oestrogen-like compounds in plants, and chlorinated hydrocarbons that act like oestrogens.<sup>14</sup>

Dr Max Cutler, a highly respected Los Angeles surgeon, gave a chilling testimony in 1970 at a US Senate hearing which was investigating the Pill. This foremost authority on breast cancer had been performing microscopic studies of biopsy material from patients who had taken oral contraceptives. "I have a series of patients who have had two or three breast biopsies. In some, the biopsies were performed before the patient started to take the contraceptive pill, and a second or third biopsy was performed after the patient had been on the Pill for several years. Study of surgical specimens under these circumstances presents a unique opportunity to observe the tissue changes."<sup>15</sup>

As Dr Cutler feared, his biopsies revealed "increased cellular activity, reflecting the stimulating effects of the oestrogen". He testified that "the risk is a potential time-bomb with a fuse at least 15 to 20 years in length...this is a gamble which is difficult to justify because of the large numbers of women at risk. The available evidence, indicating a relationship between the steroid hormones and the induction of breast cancer, suggests that this relationship is dose-related and time-related. The higher the dose given and the longer the exposure, the greater the number of cancers produced..."<sup>16</sup>

Dr Cutler's purpose for testifying was to urge that only the lowest effective doses of the Pill be prescribed and for the shortest period of time. Another 17 years would elapse before the US would heed Dr Cutler's prophetic warnings. It was only when Dr Philip Corfman became Director of the Endocrine and Metabolism Division of the FDA that the pharmaceutical industry was persuaded at last to withdraw the high-dose preparations.<sup>17</sup>

Since the development of breast cancer is related to length of use, by the late 1980s studies began to reveal the full extent of the

Pill/breast cancer link. Dr Claire Chilvers released a major study in the *Lancet* in 1989. She found that "there was a highly significant trend in risk of breast cancer with the total duration of oral contraceptives".<sup>18</sup> Women using the Pill between 49 and 96 months had a 43 per cent greater risk of developing breast cancer, and women using it for more than 97 months had a 74 per cent greater risk.

This research was further backed up by a paper, published in the *American Journal of Epidemiology* in 1989, that reported a 100 per cent increased risk of breast cancer which extended from 10 years of Pill use down to just three months of use!<sup>19</sup>

Another source of support came from Harvard School of Public Health in a review paper published in *Cancer*: "...data combined from case-control studies revealed a statistically significant positive trend in the risk of premenopausal breast cancer for women exposed to oral contraceptives for longer duration. This risk was predominant among women who used oral contraceptives for at least four years before their first-term pregnancy."<sup>20</sup>

Since the breast tissue of teenage girls is still developing and is particularly sensitive to overstimulation from synthetic oestrogen, the earlier a woman uses the Pill, the greater the risk not only of developing breast cancer but also large tumours—and a worse prognosis. In a study by Olsson (*Cancer*, 1991) it was shown that the Pill caused chromosomal aberrations in the breast tissue of young female users of the Pill.<sup>21</sup> One study found the most terrifying results: the younger the women were at the time of diagnosis, the greater the possibility they would be dead within five years.<sup>22</sup>

John Wilks, author of *A Consumer's Guide to the Pill and Other Drugs*, sums up this scandalous abuse of steroid hormones by stating that, "...given these results, it is not beyond the bounds of reasoned argument to suggest that this situation could be categorised as drug-induced vandalism of the female physiology. Yet little or nothing is heard of this lamentable betrayal of young women's health."<sup>23</sup>

Instead of relying upon the Pill to 'regulate' problem periods, girls would be much better off to correct the problem at its source through improved diet, nutritional supplements, exercise and attention to emotional stresses. It would save them from the horrors of breast cancer and the high risk of dying from the disease.

The assault on women's breast health comes not only from the effects of oestrogen but also from progestins. Depo-Provera, an injectable form of synthetic progestin, should be of great concern to women. The *British Medical Journal* reported in 1989 that women who used progestin before the age of 25 increased their relative risk of breast cancer by 50 per cent. For women using it for six or more years, the risk increased significantly to 320 per

### Minor (non-life-threatening) Side-Effects of the Pill:

- Allergic reactions
- Breakthrough bleeding
- Decreased immune system function
  - Disturbances in liver function
- Eye disorders, double vision, inflammation
  - Facial and body hair growth
  - Fluid retention and bloating
  - Fungal infections and tinea
    - Hair loss
- Hay fever, asthma, skin rashes
  - Loss of libido
  - Lumpy or tender breasts
    - Migraines
    - Nausea
- Psychological and emotional disorders, depression, mood changes
- Secretions from the breast
  - Skin discolouration
  - Weight gain
- Systemic *Candida* infection (or yeast infection)
  - Urinary tract infection
  - Vaginal discharges, including much greater tendency for vaginal thrush
    - Varicose veins
    - Venereal warts

cent. There is no doubt that progestin also stimulates breast tissue growth.<sup>24</sup>

### THE PILL AND CERVICAL CANCER

The most common cancer in young women is cervical cancer. With the introduction of the Pill, not only have the rates of cervical cancer increased but so has the incidence of sexually transmitted diseases (STDs). The sexual freedom that the Pill ushered in was also responsible for more sexually transmitted infections or venereal diseases. Dr Ellen Grant observed that, "...few of the hundreds of women I examined before the Pill was first prescribed had either cervical or vaginal infections and none of the smears was positive. Now, one in five of my preconception patients, many of whom have taken the Pill for over five years, has had a positive smear—a sign of very early cervical cancer—before they are 40 years old."<sup>25</sup>

A form of viral infection known as HPV (human papilloma virus), found in genital warts and cervical tissue, has molecular receptor sites within their respective structures which recognise and interact with hormones such as those in the Pill. Not only are the receptors within the cervical tissue adversely influenced by hormones but so are sites within the HPV which infect the same cervical tissue. The hormones stimulate an increase in the self-replication rate of the virus. For Pill users, this constitutes a form of double jeopardy.<sup>26</sup> The combination of HPV and the Pill represents a greater increased risk of cervical cancer than does the Pill alone or HPV alone.<sup>27</sup>

A 1992 study in the *American Journal of Obstetrics and Gynecology* reported that women starting on the Pill at an earlier age were at increased risk of cervical cancer compared with those starting later. The risk was 50 per cent greater for Pill users. Many studies worldwide have shown increases in both squamous carcinoma of the cervix and the rarer adenocarcinoma with prolonged Pill use. Women who have had a positive smear and continue to take hormones are more likely to develop more severe cancer.<sup>28</sup> Invasive cervical cancer in young women is another reason for early-age hysterectomy.

In addition, the Pill causes production of a type of cervical mucus which makes it easier for cancer-causing agents to gain access to a woman's body.<sup>29</sup>

Mineral and vitamin deficiencies, especially deficiencies of folic acid, have been linked with cervical cancer. Such deficiencies are prevalent among hormone-takers and smokers.

### THE PILL AND MELANOMAS

The numbers of melanomas have increased sharply among young women in the principal Pill-taking countries of Australia, North America and Europe. It has been found that the tumours, like breast cancer cells, have oestrogen receptors. It has also been

found that women on HRT are also more likely to develop melanomas. The American Walnut Creek study found that Pill and HRT users were more likely to develop melanomas. All the women who developed melanomas under the age 40 had taken the Pill. By 1981, the overall increased risk for Pill users was statistically significant at three times.<sup>30</sup>

An Australian case-control study, led by Dr Valerie Beral, described how more than five years of Pill use significantly increased the melanoma risk if the Pill had been started 10 years before the cancer was diagnosed. Dr Beral found increases among women who had been given hormones to regulate their periods, as well as hormones in HRT or to suppress lactation.<sup>31</sup>

Stress, zinc deficiency and lack of protective antioxidants increase the chance of developing moles, any of which can change for the worse when hormones are taken.

Based upon international medical research projects on the undeniable relationship between the Pill and various forms of cancer, it is quite puzzling and rather distressing that a government-approved patient information leaflet for the Pill can state the following: "**At present, there is no confirmed evidence from human studies which would indicate that an increased risk of cancer is associated with oral contraceptives.**" (Australian Government-approved drug information for Triferme, produced by Ayerst Laboratories, 1996.) The reality is quite the opposite and the evidence is indisputable.

### REGAINING PERSONAL CONTROL OF FERTILITY

Far from emancipating women, the Pill and other steroid hormone variations have condemned them to a life of potentially debilitating health risks and an early grave. We are only just beginning to realise the price we are

paying for being part of a culture where fast food, fast cures and fast sex are predominant.

There are safer, effective birth-control methods available—barrier methods such as diaphragms and low-toxin spermicides and condoms. There is also a highly effective method developed by Francesca Naish, author of the book, *Natural Fertility*.<sup>32</sup> Called "Natural Fertility Management", it incorporates various methods to monitor fertile and non-fertile times naturally, rather than override or manipulate them. Women using her technique are becoming highly attuned to their bodies and are not only reclaiming their health but are safely avoiding or achieving conception.

Maintaining choice and control over one's reproductive freedom is the right of each woman in our modern-day culture. However, perhaps it is time for women to rethink the entire Pill issue.

Women are indeed recognising that they have succumbed to a highly successful advertising and propaganda campaign promoting the joys of sexual reproductive freedom. In fact, the hidden

### Major Side-Effects of the Pill:

- Disturbance to blood-sugar metabolism (possibly contributing to diabetes or hypoglycaemia)
- Greatly increased chance of suffering a stroke (increasing with age and duration of Pill usage)
- Increased chance of hardening of the arteries and high blood pressure
  - Increased risk of blood clots
- Increased risk of gall bladder disease (gallstones)
  - Increased risk of liver tumours (as duration of Pill usage increases)
    - Osteoporosis
- Possible link with cancer of the endometrium, cervix, ovaries, liver and lungs
- Significantly increased risk of ectopic pregnancy
- Strong probability of more rapid development of pre-existing cancers and progression to cancer of abnormal cells
- Threefold to sixfold increase in risk of heart attack (according to age)

(Source: *Natural Fertility*, by Francesca Naish)

Continued on page 82



# — *The BioElites* — Engineering our Future

*Despite promised benefits, the latest developments in the human biotechnology industry have grave ethical implications for our genetic privacy and integrity.*

by Susan Bryce ©1997

c/- Post Office  
Mapleton, Qld 4560  
Australia  
Telephone: +61 (0)7 5445 7345

## THE REVOLUTION IN HUMAN BIOTECHNOLOGY

The 'gods' of the new millennium may not be aliens from another planet, but multi-billion-dollar biotechnology companies that own plant, animal and human genes. The gods will create new life through genetic manipulation, cloning and tissue culturing. Their disease-resistant creations, developed in sterile laboratories, will be the alien life-forms of the 21st century.

What happens if elite groups have control of our genetic destiny? What happens if human clones are produced; if humans are genetically adapted for deep-space travel; if education, employment and insurance are determined by our genes; if human genes become the intellectual property portfolios of transnational corporations?

The new world of human biotechnology currently being ushered in by genomic corporations, technocratic government agencies and the pioneers of medical science makes Aldous Huxley's *Brave New World* look like a freedom-loving paradise. Human biotechnology is currently undergoing a revolution. Many of the techniques Huxley envisaged for the distant future are already available or are being forecast by reputable scientists.

Human genes have become industrial commodities to be bought, sold and patented. Transnational genomic corporations, known as the "Life Sciences" industries, are swallowing up biotechnology companies, and a few enormous genomic corporations are consolidating the ownership of life.

The government-sponsored Human Genome Project, haunted by the shadow of Nazi eugenics and likened in size and importance to the Manhattan and Apollo projects, has given biotechnology a shot in the arm.

Operating in a virtual regulation and policy vacuum, where compliance to 'standards' and 'ethics' is voluntary, the rampant and uncontrolled progress of the human biotech industry has the capacity to impact seriously upon our collective destiny.

Genetic engineering and other disciplines such as embryo transfer, molecular biology and tissue culture are part of modern human biotechnology.

Biotechnology involves the development of 'products' by exploiting biological processes or substances for human purposes. It involves using organisms to provide us with food, medicine, clothes and other products. Traditional biotechnology was based on activities such as the farming of animals and plants and the use of micro-organisms in the manufacture of beer, wine, bread, yoghurt and cheese.

However, since the mid-1970s, when a small group of individuals began to realise that computers and gene sequencing were a natural marriage, advances in biotechnology have given the discipline a more menacing edge. What started as pioneering research to develop 'cures' for genetic diseases, cancer and AIDS has turned into a lucrative, profit-motivated industry.

To its advocates, modern biotechnology is ideologically neutral. Properly supported, biotechnology can bring immense benefits to humanity, for it is infinitely adaptable to counter all sorts of unforeseen threats. If we cast it down through hostility or faint-heartedness, we will be losers.

Critics see biotechnology as the expansion, misapplication and institutionalisation of a particular scientific creed, with the potential for the devaluation and exploitative manipulation of life. Jeremy Rifkin, quoted in *The Human Body Shop: The Engineering and Marketing of Life*, describes human biotechnology as "the devil at the door, cleverly disguised as an engineer and an entrepreneur".

## LICENSING LIFE: THE BIOTECH BILLIONS

On 14 March 1995, the United States Patent and Trademark Office issued the first patent on a human cell line to the US National Institutes of Health (NIH). The unmodified cell line was drawn from an indigenous person from Papua New Guinea.

Human life is now officially a commodity whose ownership can be legally enforced by patents awarded to genomic corporations on human genes and their by-products.

Since this new and outrageous era in intellectual property was launched, the 'life industries' have raced to identify and commercialise human genes and other human biological materials.

The Rural Advancement Foundation International (RAFI) describes the frenzied endeavours to profit from human biological materials as a modern-day gold rush, a gene rush:

*...silent and reckless with incalculable stakes for humankind...the commodity they seek to exploit is not gold but biological information. The raw material they need is human DNA: the blueprint of human life.*

Each human cell contains up to 100,000 genes. A single patented cell line can be worth US\$1.5 billion dollars per year to a company involved in the life sciences industries. Research conducted by RAFI reveals that more than 1,000 DNA patents on sequences have already been issued to over 300 companies and government institutions.

Just one small portion of the human biotechnology industry can yield lucrative profits. The US consulting firm Frost and Sullivan estimates that the worldwide market for cell lines and tissue cultures brought in US\$427.6 million in corporate revenues in 1996. Frost and Sullivan predict that the market will grow at an average annual rate of 13.5 per cent over the next seven years, to be worth US\$914.1 million by 2002.

Biotech companies are rushing to isolate a plethora of disease-carrying genes, including the genes that cause colon cancer, lung cancer, prostate cancer, cystic fibrosis, heart disease and asthma. Once patented, these genes are worth billions of dollars in licensing fees and spinoffs from the manufacture of other pharmaceuticals and gene technology.

Some patents already awarded include:

- The hepatitis C virus sequence, patented by the US biotech company, Chiron Corporation.
- The gene for breast cancer susceptibility, patented by Myriad Genetics.
- A European patent on the use of stored stem cells from umbilical cord blood, granted to the US company Biocyte Corporation. Such cells are widely thought to hold considerable therapeutic promise for bone marrow transplantation and gene therapy.
- The gene for H2-relaxin, a protein produced within the ovaries which relaxes connective tissue to allow a woman's pelvic girdle to widen during pregnancy and while giving birth.

Once a company has a patent (say, on a gene-sequencing right), it must be paid a royalty or licence fee by others using that sequence. Chiron claims that it invests more than five times its income from hepatitis C licensing in its research program—a total of US\$344 million in 1995. Thus, the income received from the hepatitis C virus sequence licensing fees would be valued at US\$68.8 million for that year alone.

Companies involved in human, plant and animal biotechnology

are bound up in a web of alliances and interests. Research and development is concentrated in the hands of a few companies. One example is the "superclub" set up by the France-based multinational drugs company Rhône-Poulenc Rorer, and operated by its subsidiary, RPR Gencell of Collegeville, Pennsylvania, USA.

The "superclub" is touted as an admirable venture because it will accelerate the development of gene therapies for cancer, cardiovascular disease, obesity, etc., through the use of shared data and technology. It will also accelerate the profits raked in by RPR Gencell. One of the conditions of joining the "superclub" is that researchers should withhold publication of their findings for a year until RPR Gencell files for patents to protect discoveries or inventions. This gives RPR Gencell a great deal of control over researchers' findings.

The 14 "superclub" members include:

- CNRS (France's National Centre for Scientific Research)
- Généthon, Paris
- Gustave Roussy Institute, Paris
- Transgène, Paris
- Applied Immune Sciences, Santa Clara, California
- Darwin Molecular, Seattle, Washington
- Genetix Pharmaceuticals, New York
- Introgen Therapeutics, Houston, Texas
- Lawrence Berkeley Human Genome Center, Berkeley, California
- Virogenetics, Troy, New York

Another example is the company Human Genome Sciences

(HGS) of Rockville, Maryland, which owns the details of DNA sequences that could identify 35,000 human genes—more than a third of the total thought to exist.

In October 1994, HGS announced that any researcher who wanted to use the information held by HGS could do so for free, on the basis that if the researcher came up with something that could be commercialised, such as a test or treatment for a disease, HGS would have the right to negotiate a marketing contract. HGS sees this seemingly modest demand as a way to

pay back its investors, such as the pharmaceuticals company SmithKline Beecham which has poured US\$100 million into HGS and its non-profit arm, The Institute for Genomic Research (TIGR).

In biotechnology, as in many other fields, government agencies are forming alliances with corporations. In 1995, the US Patent and Trademark Office issued a patent to the US National Institutes of Health, covering the principle of removing cells from a patient, altering their genetic makeup and returning them to the body. Almost all gene therapy trials that have been approved so far rely on this technique. The NIH has given GTI, of Gaithersburg, Maryland, exclusive rights to develop the technique commercially. Rival companies wanting to do research must now pay a licensing fee to GTI.

Alleged industrial espionage is rife as biotech companies proceed with litigation against each other. One legal battle involves mice that have been 'developed' to secrete human antibodies which may help treat AIDS and cancer. The 'humanised' mice, worth millions, were the subject of a bitter dispute between the two US companies Cell Genesys and GenPharm. Cell Genesys withdrew its legal action upon learning that the US Patent and

**Human life is now officially a commodity whose ownership can be legally enforced by patents awarded to genomic corporations on human genes and their by-products.**



Trade Mark Office had awarded GenPharm a third patent on the mouse 'technology'. Cell Genesys will now use its own patents to battle GenPharm.

#### AGRICULTURAL BIOTECHNOLOGY: THE SAME STORY

Not only is ownership of human biological materials being consolidated by "life sciences" companies; but the products of agriculture have met with the same fate.

The "life sciences" company Monsanto, with 28,000 employees, has a net worth of US\$9 billion and pours US\$200 million per year into research. Monsanto's Robert Fraley said of their agricultural biotechnology interests:

*...what you're seeing is not just a consolidation of seed companies, it's really a consolidation of the entire food chain.*

Through its shareholdings, acquisitions and licensing agreements, Monsanto has a controlling interest in the worldwide production of canola oil, soya, cotton and maize, to name a few.

Last year, the two giant pharmaceutical/chemical companies Ciba-Geigy and Sandoz amalgamated in what was the largest corporate merger in history—even larger than the Time-Life merger. The resultant new company, Novartis (whose Latin name means "new skills" or "new arts"), spans the health care, nutrition and agribusiness industries. Its estimated global net worth is 58 billion Swiss francs—more than the value of most nations. Novartis' global research expenditure for 1996 was US\$3.1 billion, while worldwide sales revenue for 1996 was US\$27 billion.

#### BIOPIRACY OF HUMAN GENETIC MATERIAL

Third world populations and indigenous peoples are currently being exploited by governments and genomic corporations seeking to commercialise genes and other biological materials.

When the US government patented the cell line of a Papua New Guinean indigenous person, there was no documentation of his informed consent or any approval from the Papua New Guinea government.

Documentation obtained by RAFI under Freedom of Information legislation revealed that the patented cells from the Hagahai indigenous person from Papua New Guinea had potential in the diagnosis and treatment of leukaemia and related retroviral diseases. These genes are now the exclusive property of the US government. Various acts of biopiracy have been the subject of investigation by RAFI, which concludes:

*Pieces of indigenous and remote rural peoples' very bodies are now, without any doubt, the potential 'intellectual property' of corporations and governments...*

Cells, DNA and other human biological materials are being shuttled into the intellectual property portfolios and cash boxes of the life industries.

RAFI has also raised concerns about the collection, handling and exchange of human tissue samples taking place *ad hoc* across international borders. Perhaps what is most controversial about the patenting of genes and the use of human biological products for profit is that it is all largely taking place in an unregulated market. According to RAFI:

*An unfortunate reality currently confronts the enormous number of people who, for clinical and research purposes, give blood or other samples of tissue. They may unwittingly*

*become a statistic in the international human tissue trade—in some cases even if the tissue donor simply gave blood for a blood bank. Donors' cells may be frozen and/or immortalized and shipped across town, across the world, or both. Genetic profile information from analysis of cells...may be created and placed in a database available to thousands.*

RAFI's enquiries revealed one Internet directory of tissue culture-related enterprises that lists 38 companies in the US which specialise in selling cells, cell products and tools for cell culturing. Some have Internet home pages where customers can peruse on-line catalogues of "normal" and/or "mutant" human tissue for sale. Human biological samples are being exchanged and used in ways that donors would not be aware of, nor would be likely to endorse.

#### THE HUMAN GENOME PROJECT

The aim of the Human Genome Project is to determine the exact genetic structure of our species—the sequence of all of our DNA. The idea for the project has been in the pipeline since the US military began studying the genetic effects of radiation on survivors of Hiroshima and Nagasaki.

In the mid-1970s, technological developments enabled researchers to use high-speed computers to sequence or map genes. Previous methods of gene-mapping relied on laborious hand-made drawings of gene maps.

In the late 1980s, biologists realised that with new technologies they could sequence the entire human genome. For obvious reasons, this 'realisation' was supported by the US government, military, educational institutions and biotech companies. The US government moved quickly to merge funding for various biotech projects.

The Human Genome Project was officially launched in 1991, funded primarily by the Department of Energy and the National Institutes of Health in the USA as well as the

European Commission.

Using high-speed computers and working with zenith nanotechnology (i.e., single molecules), the human genome is now being entered onto the GenBank database at Los Alamos (weapons) Laboratories in New Mexico, USA—site of the Manhattan Project and more recently linked to the alleged Roswell 'alien autopsy' scenario.

Researchers from the far corners of the globe are able to contribute information to GenBank via the Internet. Laboratories are offered 'incentives' to submit genomic information. Another motivation to submit information to GenBank is the growing number of journals that will not publish genomic articles without proof that the authors have submitted their data electronically to GenBank at Los Alamos.

GenBank is operated by the US Department of Energy-owned national laboratory but funded by the National Institutes of Health, the Department of Defense, the National Science Foundation and the Department of Energy. There is also a Human Genome Center at Lawrence Berkeley and at Lawrence Livermore national laboratories.

Once the first complete human DNA sequence is obtained, we will have what has been described as the 'biological grail'—a complete record of the human genome. This will be of great use to the life sciences industries because it will provide a database of

**... indigenous peoples are currently being exploited by governments and genomic corporations seeking to commercialise genes and other biological materials.**

information from which companies can obtain the DNA sequence, and hence protein sequence, of all the proteins in humans, including those which are the potential targets of new drugs. The Human Genome Project will also be of substantial assistance in medical genetics, including the diagnosis of inherited predisposition to disease.

The first complete human genome sequence is expected to be a 'composite person' with both an X and Y sex chromosome. This would formally make the 'composite person' a male, but 'he' would comprise autosomes taken from men and women of several nations: the United States, European countries and Japan. He would be a multinational, multiracial *mélange*, a kind of "Adam II", his essence encoded for the 21st century and beyond.

### THE HUMAN GENOME AS A WEAPON OF WAR

The Human Genome Project is a vital part of the US post-Cold War military strategy. Psychological, biological and defensive technology for conflict short of war is of growing importance. To this end, the human genome was recently declared a potential weapon of war.

Eighty member-countries of the Biological and Toxic Weapons Convention added "molecular biology" and "any application resulting from genomic studies" to the list of technologies, such as genetic engineering, that could possibly be employed as weapons.

Scientists are concerned that aggressors might develop a disease or poison to which only an enemy is genetically susceptible.

The member countries failed to agree to a deadline for monitoring breaches of the convention because of opposition from a group of nations including Russia and India.

In October 1989, at the Human Genome I Conference held in San Diego, USA, James B. Watson, the Human Genome Project's first director (and co-discoverer of DNA's structure in 1953) told the audience:

*We have to be aware of the really terrible past of eugenics, where incomplete knowledge was used in a very cavalier and rather awful way, both here in the United States and in Germany. We have to reassure people that their own DNA is private and that no one else can get it...*

In light of the above reports about gene patenting, it would seem that Watson's words of caution fell on deaf ears.

### HUMAN GENOME DIVERSITY PROJECT

The Human Genome Project should not be confused with the Human Genome Diversity Project (HGDP), which is a separate but related project concerned with collecting cells from over 700 indigenous clans and tribes worldwide.

The unscrupulous methods for collecting cells and the trafficking and trade in indigenous people's biological materials is well documented by the Rural Advancement Foundation International.

The US Navy has also been undertaking its own private research activities involving the collection of cells and tissues from remote tribes and clans in Indonesia, Papua New Guinea, Peru and Colombia. Of particular interest are blood samples containing the retrovirus HTLV-1.

The previously mentioned Hagahai cell line, patented by the US National Institutes of Health, contains the human leukaemia retrovirus HTLV-1. Thymus lymphocytes (T-cells) can be separated

from HTLV-1 blood samples.

As documented by RAFI, several key US research institutes—including the National Cancer Institute and the Centers for Disease Control—and the US Navy have global research programs tasked with collecting blood samples for HTLV-1 research.

Some readers of *NEXUS* will be familiar with the AIDS-HTLV link, reported in 1988 (see the *NEXUS* supplement, *AIDS: The Real Story*). HTLV-1 can be used to manufacture large quantities of the AIDS-related virus, HTLV-3.

### NAZI EUGENICS AND ECONOMIC RATIONALISM

A plethora of ethicists and historians have raised concerns about connections between experimental processes involving human biotechnology and the Nazi 'legacy'.

Nazi genetic experiments were not an historical aberration that can be dismissed. The forces that inspired them did not die with them. The Nazis drew inspiration from many sources, not least of which was the eugenics movement in the USA.

Indeed, fear of a eugenics revival is a key anxiety surrounding the Human Genome Project in the United States and Europe.

Eugenics involves any attempt to improve the biological character of a 'race'. Under Adolf Hitler, German scientists—among the most respected in the world before the Nazi era—took part in an ignominious attempt to create an Aryan blue-eyed, blond-

haired master race through genetic manipulation and experimentation.

In a paper titled "Nazi Biomedical Policies", published in the book, *When Medicine Went Mad*, Robert N. Proctor gives this stern reminder:

*The Nazis sought to transform problems of racial, sexual or social deviance into medical problems; Germany's social and political problems would be solved by diagnosis, disinfection and surgery. Murder was practised in the name of quarantine; apartheid in the name of public*

**"...once the human genome has been mapped, it has the potential to become a standard, or norm, for all people—against which we will then be measured for our normality or abnormality."**

*health...*

Could modern 'eugenics' programs be prompted by the engine of economic rationalism now driving the economies of most nations? Policies are characterised as eugenic if their intent is to further a social or public purpose, such as reducing costs or sparing future generations unnecessary suffering.

Could genetic inheritance become a new basis for discrimination? This was a topic of discussion at the Human Genome Organization's Second International Genome Summit, held in Canberra, Australia, in October 1996. It was an informal meeting of about 50 people. Australian GeneEthics Network Coordinator Bob Phelps was the lonely voice of the people in a wilderness of heavyweight experts including scientists and lawyers.

The GeneEthics Network is involved in lobbying against genetic engineering of plants, animals and humans and raising public awareness of biotechnology. Most recently the network has been involved with a campaign against Monsanto's "Roundup Ready" genetically engineered soybean.

At the Australian Genome Summit, one participant, Dr David Cox of the Stanford School of Medicine, California, USA, stated:

*Genetic discrimination to exclude people from employment, insurance and access to health care is a potential adverse consequence of the data generated by the Project. Protection against such discrimination should prevail over conflicting*

*societal values; such protection must be mandated...*

Despite moves in the US and Europe to tighten controls on genetic discrimination, to date no such protection exists in Australia.

Bob Phelps of the GeneEthics Network told this writer that: *...once the human genome has been mapped, it has the potential to become a standard, or norm, for all people—against which we will then be measured for our normality or abnormality. It is going to lead potentially to some great discriminations and other adverse social consequences...*

This has great significance for us all. The coercive forces of economic rationalism that equate progress with cost efficiency could dictate that it would be cost-effective to reduce the number of genetically disabled people. People with disabilities or illnesses could become doomed by their genes. Public policy could pressure or even compel people not to bring genetically damaged children into the world for the sake of the gene pool and in the interests of keeping down public health costs.

New genetics techniques that might extend our lives could justify experiments on the terminally ill on the basis that they are 'doomed anyway' and so have 'nothing to lose'. Equally, projects that generate large incomes for researchers and potentially huge profits for private corporations could be oversold.

George Annas, lawyer and Professor of Public Health at Boston University, says there are powerful forces at work in our society that could combine to affect dramatically the rights and welfare of the less than genetically perfect, creating a culture in which people are valued and devalued based on their genetic endowment. Embryos could be screened and nurtured based on genetic quality.

Writing about the Human Genome Project, Annas says that our fetish for efficiency, our quest for immortality, our belief in commercialism and its handmaiden hype will continue the slide down the slippery slope. The question now is: how far and how fast?

## THE BIO-ELITES' VISION FOR THE FUTURE

The brave new future that Aldous Huxley depicted is already upon us, with many techniques he envisaged already available or at least being taken seriously by reputable scientists.

The 1995 "foresighting program" conducted by the Australian Science and Technology Council (ASTEC) provides an insight into the future. Under the heading, "Scenario for 2010: Impact of Research into the Human Genome and Environmental Impact on Health", ASTEC suggests that our future may be determined by a genetic profile—which would determine that individuals should eat certain designer foods and have certain designer therapies throughout life to prevent the onset of genetic disease.

If people were not willing to be engineered in such a way, they could be refused insurance, employment and education. This way, genetic destiny would be manipulated by designer foods and designer therapies.

The advocates of the recently developed concept of "auto-evolution" theorise that elite groups of humans should use existing gene technologies to start directing the evolution of their offspring. Auto-evolutionists envisage that in six generations, or 350 years, humans would be unrecognisable.

Other more exotic schemes include 'adapting' humans for deep-space travel. This may sound like a giddy science fiction scenario, but, already, one Australian company is developing pine and eucalypt species that do not require open pollination. It was shown in studies carried out in the "Biosphere" project that the pollinators had difficulty surviving. Is the biotech industry readying to create artificial environments outside the Earth's biosphere in deep space?

Could we 'adapt' the human species to explore the deep oceans, or 'produce' soldiers resistant to agents of biological war? Such proposals are currently under consideration.

In publicity over the recent cloning of "Dolly" the sheep, it seems to have been forgotten that human embryos have already been cloned. In 1993, researchers Stillman and Hall, of George Washington University, USA, cloned 48 human embryos, none of which grew for more than six days.

Dolly, the cloned sheep, born at the Roslin Institute in Scotland in July 1996, was 'unveiled' in February 1997 after patent applications were filed and research papers prepared for publication. The non-profit Roslin Institute is part-funded by PPL Therapeutics, a biotech company formed in 1987 to commercialise the Roslin Institute's research.

According to RAFI, PPL Therapeutics has several human protein products in development and holds a US patent on a method

to produce therapeutic proteins in the milk of transgenic sheep. PPL has research agreements with at least four major pharmaceutical corporations including Novo-Nordisk, American Home Products, Bayer and Boehringer Ingelheim.

Scientists believe that cloned animals with genetically engineered traits will become highly efficient, living drug-factories for 'use' in the manufacture of therapeutic proteins. The market for therapeutic proteins is currently about US\$7.6 billion per annum and is expected to grow to

US\$18.5 billion by 2000.

Cloned animals could be exploited as 'spare parts' factories for humans. Transgenic pig clones, for example, could be genetically engineered to be a source of replacement organs for humans.

In the twilight years of the 20th century, human biotechnology joins the ranks of environmental decay, nuclear conflict, surveillance technology, monopoly ownership and government-sponsored corporatism as one of the most dangerous threats to our physical, intellectual and spiritual freedom.

The slide down the slippery slope has already begun, but public opinion *can* dictate how fast and how far we go. If we do not act now, our future will be determined by the bio-elites. ∞

## References: Books

- Annas, George J., "The Human Genome Project in Perspective: Confronting our Past to Protect our Future" in *When Medicine Went Mad: Bioethics and the Holocaust* (Arthur L. Caplan, ed.), Humana Press, Totowa, New Jersey, USA, 1992.
- ASTEC (Australian Science and Technology Council), "Developing Long-Term Strategies for Science and Technology in Australia", findings of the study, *Matching Science and Technology to Future Needs 2010*, Australian Government Publishing Service, Australia, 1996.
- ASTEC, *Gene Technology Issues for Australia*, Occ. Paper No. 27, AGPS, August 1993.
- Bains, William, *Biotechnology from A-Z*, Oxford University Press, UK, 1993.
- Cook-Deegan, Robert, *The Gene Wars: Science, Politics and the Human Genome*, W. W. Norton & Company, New York, 1994.

Other more exotic schemes include 'adapting' humans for deep-space travel.

Continued on page 83



# ***A Radical Cancer Treatment Using Electromagnetism***

***For many years,  
Jerry Jacobson has  
been promoting his  
paradigm-busting  
approach to  
treating cancer,  
AIDS and other  
diseases, yet his  
attempts to secure  
sufficient funding  
for experimental  
trials have been  
stymied.***

**by John Chambers ©1996**

22491 Vistawood Way  
Boca Raton, FL 33428, USA  
Telephone: +1 (561) 482 5971  
Fax: +1 (561) 852 8322  
E-mail: [jdc@flinet.com](mailto:jdc@flinet.com)

## **A GENIUS INVENTOR/THEORIST FIGHTS THE FORCES OF SUPPRESSION**

**C**an electromagnetic fields, only one ten-millionth of the Earth's gravitational field in strength, cure cancer by 'jiggling' masses from the subatomic to the molecular in such a way as to provoke the oncogenes in malignant cells to revert to normal genes? No, says conventional medical wisdom. Yes, says Dr Jerry I. Jacobson, 50, head of the Perspectivism Foundation in Jupiter, Florida, USA.

At least two world-class medical researchers think Jacobson is right. "Jerry Jacobson should receive the Nobel Prize for Medicine," says Prof. Björn Nordenström, M.D., Ph.D., of Stockholm, Sweden, chairperson of the Nobel Committee on Medicine in 1985-1986. Dr Nordenström is the inventor of balloon catheterisation and the needle biopsy (a technique using X-ray guidance to insert a needle through the body wall into a suspected tumour to remove a tissue sample).

For Dr William S. Yamanashi, Professor of Medicine, Cardio-Vascular Section, at the University of Oklahoma, Oklahoma City, USA, Jacobson is a trailblazing thinker who should be taken with great seriousness. "Jerry has had an important insight into electromagnetism and its application to biology," declares Korea-born Yamanashi, himself an early pioneer in magnetic resonance imaging research and developer of the first interstitial hyperthermia performed under an MRI device. Jacobson's insight, affirms Yamanashi, has "far-reaching implications, even beyond those in medicine".

Both researchers acknowledge that the proper application of what is now, in scientific circles, termed "Jacobson Resonance" will be difficult. Jacobson has shown that healing can only be effected if the precise amount of electromagnetism required, in the function of particular diseased cells, is calibrated using no less complex a yardstick than Einstein's theory of relativity. Jacobson says this entails calculating the interrelation of inertial velocities such as the orbital velocity of the Earth, the length of the organism (i.e., the patient), magnetic fields such as the Earth's steady magnetic field, and critical molecules in biological systems.

For close to two decades, and in particular over the last five years, Jacobson, originally from Brooklyn, New York, has been trying to secure venture capital to put into practice his revolutionary techniques which, he says, can also cure AIDS and other diseases. But the tall, wiry Brooklynite with the curling grey hair and misty black eyes already has two strikes against him. The first is that, although he has had more than 50 peer-reviewed papers explaining his ideas published in the world's most reputable medical journals, and, in the bargain, has published two books with the prestigious Philosophical Library Press in New York, he still lacks the conventionally acceptable academic qualifications, for Jacobson is not a medical doctor, but a dentist; and, though he has taken two dozen courses in the field, he does not have a Ph.D. in physics.

The second difficulty Jacobson must contend with is that not only do his concepts go completely against the grain of accepted scientific wisdom, but they are deeply threatening to the medical profession. If the now-retired dentist's ideas were successfully implemented, they would render obsolete the work of literally millions of doctors. And that possibility, claims Jacobson, provoked a harsh response from the American Medical Association (AMA) when he first sought to promote his ideas.

In 1981, when then-Brooklyn-based dentist Jacobson called a major press conference in New York City to announce his revolutionary cure for cancer, not a soul attended. Invitations had been sent out to several hundred dignitaries. Some, like New York State

Governor Mario Cuomo, had given their word they would come. The press conference was held one floor above the famed Sardi's Restaurant in Manhattan, in conjunction with a Salmagundi Art Club painting exhibition that Jacobson had organised to add interest to the press conference for those who had been formally invited and to serve as an enticement for those who might have heard about it in some other way.

But not a single person showed up to hear Jacobson's announcement and request for funding. Jacobson, then 34, was already not only a successful dentist with two patents to his credit, but also a painter whose works were frequently exhibited in art galleries in New York, a clarinetist who performed in nightclubs around the city, the author of a book, *Perspectivism in Art*, on the relationship between art, philosophy and science, and, two years later, a second work on the same subject, titled *The Meaning of Life*.

Jacobson had singlemindedly been pursuing a cure for cancer ever since he had been a student at middle school. But the appearance of dilettantism would be exploited by his rivals. His vulnerability as a dentist was already being exploited. In the year following the abortive press conference, Jacobson's practice was successfully sabotaged by a deliberately inept, record-tampering assistant dentist who eventually confessed to being in the pay of the FBI.

It was then that Jacobson became certain of what he had been increasingly suspecting: that the AMA, its ways of thinking deeply threatened, was collaborating with federal law enforcement agencies to make sure the Brooklyn dentist/theoretician's paradigm-busting new approach to the treatment of cancer would never see the light of day.

By late 1983 Jacobson's dental practice had been destroyed, and the multi-talented researcher had moved to Florida and semi-retirement with his wife, Debra, a dancer, and their two children (they now have four). Settling in the oceanside town of Jupiter, just 25 miles north of West Palm Beach, Jacobson set about establishing the credentials he now felt he needed if he were to find funding for his ideas.

Within a decade he had published more than 50 peer-reviewed papers in professional publications such as the *Journal of Theoretical Biology*, the *Israeli Journal of Medical Sciences*, the *International Journal of Neuroscience* and *Panminerva Medica*.

During that time he was also able to increase the number of his patents to four in the US and 20 overseas. Among them was a patent for the basic design of the sophisticated equipment he would need to provide patients with the treatment over which he had theorised for years.

Over this ten-year period, Jacobson had also been a speaker at more than two dozen conferences worldwide, including two international meetings convened by his now-friend Dr Björn Nordenström, in Stockholm, Sweden. A leading cancer researcher at Sweden's Karolinska radiology institute in Stockholm, Dr Nordenström has in recent years developed a controversial electrochemical method for treating cancer. In the late 1980s he founded the related International Association for

Biologically Closed Electric Circuits (IABC). In 1993 and 1994, Dr Nordenström personally invited Dr Jacobson to be a guest speaker at the association's annual conference in Stockholm.

Over the years, Jerry Jacobson has written eloquently about his theories and methodologies. As he conceives the treatment protocols, the patient would be placed inside a multi-coiled length of wire in a tub filled with water to promote conductivity. A weak electrical current would be sent through the wire, producing a carefully calibrated magnetic field within the coil which would pass through the patient and regulate, "in a resonant situation", the structures of relevant genes, RNA, growth factors and enzymes.

In a paper published in the *Israeli Journal of Medical Sciences* in March 1994, Jacobson described his theory, its application and its effects in the following way:

"Let us consider the possibility of using an extremely weak extrinsic magnetic field to treat various diseases by placing human organisms in water to promote conductivity. We might place the patient within a large coil of wire immersed in water. The coil would be connected to a power source which would be regulative, and a weak electrical current sent through the wire would produce a very well controlled magnetic field within the coil which would cut through the patient.

"If we viewed the patient as a straight conductor and placed the patient at right angles to the magnetic lines of force in the coil, we could induce an electromotive force across the patient's body. (The magnetic field lines would all be relatively parallel to one another in the axial centre of the conductor.) In so doing, we might attempt to regulate in a resonant situation the structure of genes, RNA, growth factors and enzymes.

"Consider an oncogene. The energy in a given oncogene is determined by Einstein's formula,  $E = mc^2$ , where (m) is the molecular weight or mass of the oncogene, the transforming DNA segment; (c) is the speed of light; and (E) is the intrinsic energy of the gene.

"If we then utilized Michael Faraday's expression,  $E = BLV$  [namely, (E), or the induced EMF, is equal to the magnetic field (B) times the velocity (V) of a conductor of length (L)], we could calculate the electromagnetic interaction energy that was produced by the interaction of the patient with a particular magnetic field exogenously applied. EMF is energy per unit charge. Therefore,  $mc^2 = BVLq$ .

"In this model, (L) is the height of the patient. Let's say we have a patient about six feet tall who is traveling with the Earth at an orbital velocity of 18.5 miles/sec. There is an interaction between the patient and the magnetic field. Since the magnetic field travels at the speed of light, according to Einstein's theory of relativity, the magnetic field is not said to be travelling with the Earth as the patient is. The particles that make up the field are independent of the inertial frame of reference. This means that the interaction between the patient and the magnetic field would be instantaneous. The result would be a gravity wave that would travel through the patient.

**It was then that Jacobson became certain of what he had been increasingly suspecting: that the AMA, its ways of thinking deeply threatened, was collaborating with federal law enforcement agencies to make sure [his] new approach to the treatment of cancer would never see the light of day.**

"According to Einstein, gravity waves jiggle space and influence the structures of masses just very slightly. We propose that we can jiggle the oncogene by setting up a resonance condition in which the energy of the electromagnetic interaction is equal to the inherent gravitational energy of the oncogene in terms of its mass. We might then induce a vibration of the crystalline lattice of the oncogene. Some specific examples of these proposed correlations have been published, relating specific oncogenic masses to previously measured magnetic fields associated with the brain and the heart...

"It is speculated that the jiggling of the transforming DNA segment would reorient the atomic crystal lattice structure and convert the oncogene back into a normal gene. It is also speculated that base substitution, that single point mutation that has created the cancer gene, could be negated by shaking the erroneous substituted base out of the space; and the appropriate base could then jump into that space. If these weak magnetic fields are physiologic, we can easily assume that the jiggling of the mass would not harm genes that are normal and of the same mass."

**I**n the early 1990s, Jacobson received affirmation of the correctness of his approach with the publication of separate research reporting success in the treatment of Parkinson's disease, epilepsy and multiple sclerosis using picotesla (extremely weak) electromagnetic fields.

The researchers were Dr Reuven Sandyk, of the Department of Psychiatry at Albert Einstein College of Medicine in New York, and Drs P. A. Anninos, N. Tsagas and K. Derpapas, all of the University of Thrace in Greece. The 'dosages'—ranges of about 400 to 1,200 femtotesla for epilepsy patients, and a field magnitude of about 7.5 picotesla to treat Parkinson's disease—were close to those predicted by Jacobson using relativity theory.

Though later independent research would suggest, to some, that the cures effected in the course of the American-Greek research were shortlived, at the time the discovery created enough excitement to elicit a laudatory article from at-first-sceptical *Science Magazine* editor Dr Sidney Weinstein who went especially to Greece to view the results.

Jacobson had developed his concept of Jacobson Resonance independently of other researchers who, as far back as 25 years before, were already laying the groundwork with key discoveries.

In 1971, Denis Cohen demonstrated that very weak magnetic fields are associated with brain waves—specifically alpha and delta waves.

Other researchers had shown that very weak magnetic fields are associated with the human heart—fields one to ten million times weaker than the normal steady field of the Earth, which is a weak field itself.

The magnetic field of nerve impulses, also first measured in 1971, was found to be approximately a million times weaker than the Earth's magnetic field.

M. Zanakis and M. Politis demonstrated in the 1980s that sharks, rays, monkeys and humans display electrical sensitivities from a tenth of a volt per centimetre down to the level of a tenth of a microvolt per centimetre. The two researchers were also able to show that electrical currents in the order of a

microampere are associated with human functioning.

Jacobson himself has written that, "It was McClintock who first showed us that genes do not occupy stable loci; they move. They do not crawl as does the cystic fibrosis gene; they jump as well." Such observations suggested that if a gene could be appropriately stimulated it indeed would have the ability to change place—an effect that Jacobson had predicted through his theorising.

Late in 1994, significant support came for the Jupiter, Florida-based thinker/researcher in the form of proposals from three universities—Baylor, in Houston, Texas; the University of Nebraska, in Omaha, Nebraska; and the University of Oklahoma, in Oklahoma City—to research aspects of the application of Jacobson's theories.

The Baylor College of Medicine Department of Molecular Physiology and Biophysics, for one, proposed to "...study the interaction of extremely weak magnetic fields (i.e., the range of Jacobson Resonance) on cells, organelles and molecules, using the technology of scanning tunnelling microscopy (STM)." The first year was to be spent upgrading the STM electron microscope so that it would be powerful enough to observe Jacobson Resonance, wrote Chief Investigator Dr Carlton Hazlewood. Two more years would be required to carry out the actual experimentation, with total costs running to an estimated US\$400,000.

Yet, despite the seriousness of these proposals, Jacobson's Perspectivism Foundation has had great difficulty raising the necessary matching funds. Jacobson senses that there is a still-to-be-expected—perhaps in some ways subtly orchestrated—resistance to his ideas.

In September 1994, Jacobson made a second major attempt to go public with requests for funding, this time introducing at a press conference Angelie Diya—a ten-year-old girl, also of Jupiter, Florida, who was born HIV-positive and developed AIDS earlier that year. Angelie, said Jacobson, represented the sort of human tragedy he could avert if he were given the means to put his theories into practice.

CBS-TV, which had taped a story about an AIDS children's summer camp that Angelie had attended, was present at the press conference. In the coming months CBS taped extensive footage



Dr Jerry Jacobson (left), with Dr Björn Nordenström at the 1994 IABC Conference.

of Jacobson, including interviews, making him, his views and activities an integral part of a two-hour documentary, *Angelie's Secret*, which was aired nationally in the US in June 1995.

Yet, though Jacobson had finally received the kind of national exposure he needed, the CBS program largely succeeded only in suggesting, by focusing mainly on the scientist/thinker's non-medical interests and talents, that Jacobson was a sort of amateur "Renaissance man" whose activities should not be taken seriously, and even that he might be, however subconsciously, something of a con artist. The program failed to mention Jacobson's multiple publications and medical conference appearances, and the success he has had in obtaining from reputable universities proposals for the development of his ideas. Though it briefly showed the group, it did not mention the dedication of a number of publicists who had quit their jobs to work full-time, at no salary, raising funds for Jacobson.

**T**he CBS treatment of Jacobson raised the spectre of organisations like the AMA and the FBI moving in determined if shadowy fashion behind the scenes to make sure Jacobson did not get the funding that he needed.

"Jerry is the smartest man I have ever known, and also morally the best," says Harvey Grossman, who quit his position as executive director of the prestigious Weissman Institute in West Palm Beach, Florida, to act as director of publicity for Jacobson. "The tragedy is that the world may simply not be ready for him."

A spokesperson for the national American Cancer Society in Atlanta, Georgia, says he has heard about "numerous variants" on Jacobson's theories, and refers all reporters to the newly-formed Office of Alternative Medicine of the US National Institutes of Health. The Office says the field of alternative medicine is so "unregulated", and its own operations so new, that its policy is not to comment on the effectiveness of alternative medicine or practices.

The odds seem stacked against Jacobson, despite his brilliance and his determination to fight. He has focused his energies on

finding a cure for cancer since the age of six—when, one day, his father arrived home from an unexpected stay in hospital to announce in a whisper to his horrified son that he had cancer of the larynx and that his larynx had just been removed. He did not go the normal route of a medical researcher, he says, because he felt his mind should remain free of the influence of all 'authority'.

Even now, Jacobson, together with Dr Nordenström, is planning an international conference, to be held in West Palm Beach, that will bring together 300 international scientists who are

involved in the use of Nordenström's electrochemical treatment (ECT) against cancer. The conference will include 30 scientists from China, where the Swedish scientist's innovations are meeting with significant success.

Jacobson's determination to fight on is the best indication that this bold adventurer into forbidden realms of medical wisdom might one day escape from the visible and not-so-visible coils of the forces that suppress revolutionary scientific thinking in our world today.

**In the early 1990s, Jacobson received affirmation of the correctness of his approach with the publication of separate research reporting success in the treatment of Parkinson's disease, epilepsy and multiple sclerosis using extremely weak electromagnetic fields.**

**For further information, contact:**

Foundation for Jacobson Resonance  
17829 Pine Needle Terrace, Boca Raton, FL 33487, USA  
Telephone: +1 (561) 997 8833; Fax: +1 (561) 989 0335  
E-mail: fjr@aksi.net Web page: <http://users.aksi.net/~fjr/>

**About the Author:**

A native of Nova Scotia, Canada, John Chambers holds an M.A. in English from the University of Toronto. He has worked as a full-time instructor in English at Dawson College, Montreal, Quebec; and as a senior editor with McGraw-Hill Publishing Company and a managing editor with International Thomson Transport Press, both in New York City. He currently lives with his family in Boca Raton, Florida, where he writes articles on 'new age'/'new paradigm'/anomalous phenomena-related subjects and is an adjunct professor of writing at Florida Atlantic University.







# ***BRIGHT SKIES***

## **Top-Secret Weapons Testing?**

***Strange light-events  
have been reported  
over many remote  
parts of Australia in  
recent times.***

***With the meteor  
theory ruled out,  
could these energy  
bursts and beams  
be part of some  
classified Tesla-style  
weapons program?***

### **Part 2**

**by Harry Mason, B.Sc., M.Sc.**

©1997 All Rights Reserved

1313 Armstrong Road  
Jarrahdale WA 6203, Australia  
Phone: +61 9 525 5999  
Fax: +61 9 525 5944  
E-mail: orbitx@ois.com.au

#### RECENT EXOTIC AUSTRALIAN LIGHT-ENERGY EVENTS

**W**hilst researching the 1993 Banjarn fireball-explosion-earthquake incident, I became aware of an entirely different spectrum of bizarre, non-fireball-related light phenomena events reportedly being observed in our skies by very reliable Western Australian bush observers (such as those who described the fireballs over the town of Tom Price). In common with the fireball events, these events were rarely, if ever, being reported in the press and do not appear to have been commented upon by our scientific community.

These events vary in style, but nearly all involve essentially static atmospheric light-emission events that have apparently never been reported or observed before the 1980s, have been reported rarely post-1985, but now have an increasing event periodicity in post-1993 years.

One such event type commonly reported consists of massive high-energy five-to-ten-second bursts of blue-white light seen in the night-time skies of the upper atmosphere. Such events have been reported in WA by many observers including meteor experts and amateur astronomers who are categorically certain that these are *not* transient light bursts due to single meteors or multiple meteor showers.

Normally, no massive object or moving light source is seen in association with these events. However, the massive blue-white light energy emissions are at times quite similar in power output to those very bright, blue-white light flash events often reported occurring in conjunction with fireballs and their 'explosion' (as described in Part 1 of this article series).

Similar events involving massive blue-white light burst emissions have also been reported as occurring at ground level. For example, one October 1994 incident that was seen from Minara station (50 kilometres east of Leonora in the Eastern Goldfields of WA) possibly involved a night-time UFO landing and small beings with torches combing around the station buildings. The exotic, brilliant blue-white flare was observed at ground level as the alleged alien spacecraft accelerated off the nearby Minara airstrip. The light from this flash lit up the entirely dark station buildings in a brilliant and "beautiful" blue-grey glow silhouette.

Another 1996 night-time incident was observed near Rocky Gully in the south-west of WA and was described as a very scary event where massive blue-white streamers of arcing electricity issued from the forest floor into the atmosphere, creating an intense, violent, blue-white glow (and an attendant "electrical noise") that was visible for miles—"like someone with a giant arc welder". This event persisted for at least several minutes. The observers fled the area in fear for their lives, phased out by the apparently enormous energy involved in the event.

These massive energy bursts of high-altitude, blue-white light and/or ground-level electrical arcs are reasonably common and I have about 100 such documented events in the WA database. Publicity from my first NEXUS article has resulted in three similar events—one of them from eastern Victoria—being reported to me. I am unaware of any such similar events being reported historically in the literature anywhere on planet Earth—except as referred to below in connection with circa-1900 high-frequency, high-voltage EM wave experiments by Nikola Tesla.

Other exotic events involve post-1993 night-time and daytime observations of golden-orange or silver-blue-white beams or cylinders of energy propagating vertically downward from high altitude and hitting the Earth's surface—with no noise or surface damage and no thunderstorm activity reported—usually in isolated outback areas.

Another style of light-energy emission event being observed involves orange-red- coloured forms hanging statically in the night sky. Commonly pencil-beam-shaped (vertical or at 45 degrees), but including rare spherical forms, this style of event has been reported since about 1985, with an apparent increase since about 1990 but with many more sightings reported since 1993. Some 100 such events have been reported.

Luckily, in this case, an alert amateur meteor astronomer, experienced in night-time astrophotography, has captured one such case on film. John Goldsmith photographed this beam from his home in Bedfordale (east of Fremantle in the Darling Ranges) at about 9.50 pm on 24 May 1990. John's photographs are shown on the following pages.

I took a compass reading (at the spot indicated by John Goldsmith near his telescope observing platform) across the trees as visible in photos 2-4. The bearing was about 262-263 degrees magnetic (local deviation is a degree or less as is the compass and reconstruction accuracy). The beam bearing is on a direct line to the "prohibited" area of the Fremantle Garden Island Naval Base.

This "island", or promontory, is riddled with underground installations from World War II when it was used as a submarine base by the US Navy/British Royal Navy/Royal Australian Navy. The southern end of Garden Island is occupied by HMAS *Stirling*—our current submarine base—where most of the Australian Collins Class subs are to be based. Naval yards are also present under the beam bearing on the mainland.

Although we cannot deduce the exact range of the beam, it has to be fairly close to the observer as it is in front of the clouds and lights up some of them. It is therefore a good bet

that this beam was hanging above, or very close to, the Garden Island naval facility.

John Goldsmith had come out of his house that night to do some astronomical telescope work. He saw the orange beam hanging vertically in the sky and raced back inside for his camera. Being used to capturing transient meteorite events, he knew exactly how to set up the photo. He used 400 ASA film on settings of 30 seconds, 60 seconds, 120 seconds and 120 seconds for photos 1 to 4 respectively.

John stated that the beam lit up some clouds and was not as bright as the images captured on film—probably due to light capture in the exposure time, or perhaps his recall of the intensity is a bit out. The beam did not appear to move around or change much over the five to six minutes that it was in view, but John was concentrating hard on the camera.

A video reconstruction utilising his four photos, each registered on the same bright stars, demonstrates that, indeed, the beam location is entirely static over the duration of the event. Finally, after about five to six minutes, the beam just faded away to nothing. There was no sound event.

The stars are seen to move over the exposure time, and possibly the centre of orange light intensity changes a bit, downwards along the beam. The overall beam light energy varies up and down in intensity from photo to photo—possibly due to the vary-

ing film exposure times or variations in the beam's actual light-emission intensity.

On the original colour photos one can see beside the orange beam a band of weaker red lines, then blue lines, then an even weaker band of red lines, and then blue lines again, as follows (to the left of the major beam): O RRR BBB rrr bbb, and so on. Note that similar spectra also exist to the right side of the beam. The spectral lines are distributed either side of the major orange beam across a considerable width of sky—at least twice the length of the visible beam length and possibly more. These photos also suggest that a 'ghost' basal tail of the central major beam goes much lower, possibly to ground level.

The photos were taken in the dark at about 9.50 pm (sunset here in WA on 24 May 1990 was at about 5.30 pm). Note that the near-vertical white line on the left hand side of image no. 2 is an original film glitch and not an event of the time.

It was originally suggested that this beam was an effect created by a ground-based laser, but checks by atmospheric scientists who employ such devices in Australia and the USA have completely

discounted such a theory. One major problem is that the light-form appears well up in the atmosphere and is not connected to any ground-based laser. Another problem is the large width of the beam when compared to normal pencil-thick laser probes which are normally only visible within two kilometres of the beam. In addition, there are harmonic spectral lines visible across the image.

Another suggestion was that the beam is a searchlight, yet it cannot be a normal searchlight as it appears at high altitude with no connection from ground level. It also has no conical section diverging upwards, and it



Photo #1 of orange light beam over Fremantle Garden Island Naval Base on 24 May 1990 (© John Goldsmith)

has exotic parallel harmonic spectral lines.

In 1991 a Japanese astronomy magazine published an article with a very poor black/white version of the photo, suggesting the main beam was caused by refraction of ships' lights by a horizontal layer of different density air. If so, why has this effect not been previously documented anywhere over the world's oceans?

I now have many eyewitness accounts of such vertical orange beams seen at night over land over the past two years here in WA. These land locations are generally uninhabited and have no light sources (such as searchlights, etc.) for refraction by air layers as suggested by the Japanese magazine.

One 1996 Brisbane beam event report was very significant as the observers saw very-high-voltage, blue-white discharge streamers issuing from their house wall-mounted mains power box as an orange beam hovered nearby in the sky. Members of another household reported their power box hummed violently as the orange beam hovered some distance away in the sky.

This data confirms the probability that Tesla-style longitudinal scalar EM potentials were involved in this Brisbane event (and therefore were possibly present during the other beam events), probably created by a remote Tesla EM transmitter and issuing from local space-time 'vacuum' at the standing wave target node, i.e., the beam location.

One quite feasible explanation for the orange beams is that they

are due to electromagnetic 'holograms' of light-energy being emitted from invisible but concentrated slugs of EM standing waves. Such waves may be of natural (e.g. Earth stress lights), human or alien origin, but all involving multiple scalar EM wave interference.

The massive, high-altitude, blue-white light energy flashes are possibly due to Tesla EM wave emission coupling briefly with the upper atmosphere, whereas the ground-level flashes are possibly due to the operation of a Tesla Magnifying Transmitter (located either in Australia or overseas) that is transmitting EM energy through the planet to the antipodean target site where electrical arc energy is being violently released.

None of the reported events involving either blue-white light energy flashes or orange-red beams or spheres occurred during or near any kind of electrical storm or unsettled weather pattern. There is a possibility of some unknown natural phenomenon electrically charging selected Earth fault plane systems across WA, thence creating huge "Earth stress lights" hanging above selected energy concentrations.

Solar charged-particle output, coupling in some peculiar style with the Earth's ionosphere/surface, is a further possibility, but this implies that there has been a very significant recent change in the Earth-Sol electromagnetic and/or electrostatic equilibrium.

Such powerful and localised exotic light events, occurring in large numbers and in such a relatively short time-span of a few years, have never been previously reported from WA, or anywhere else on planet Earth, in documented scientific history.

However, on occasion, isolated single high-energy (Earth stress light?) events have been reported; e.g., in Eastern Tibet in 1947, prior to the Red Chinese invasion, a large earthquake struck this border area and was followed by huge, high-power, orange-red glows of spherical light-forms which hung for days over the eastern sky. Buddhist monks reported that these apparitions were visible from Lhasa and they considered them at the time to be very evil omens (and correctly so!).

These Australian events are very high-power events and should not mistakenly be compared with the average, isolated and very rare, low-power "Earth stress light" and/or "min-min light" reports as occasionally observed near seismically active earthquake zones and only rarely reported in historical literature.

The concentrated high energies involved in the recent Australian fireball and associated events and in the exotic static light events, as well as their increasing event periodicities, suggest a non-natural origin, or possibly a rapidly evolving natural system of unknown type.

At this time, scalar EM wave interference is the preferred physics mechanism for the formation of both fireballs and their associated phenomena as well as the exotic static light emission events.

Alien UFO activities cannot be completely discounted, but they do not fit the available human intelligence pattern which strongly points to Earth-based technological activity.

## BANJAWARN NUCLEAR BOMB SCENARIO?

During my early research enquiries in 1995 into the "Banjawarn Bang" of 28 May 1993, Australia's ABC radio broadcast a news item from the USA referring to US Senator Sam Nunn who was chairman of a US Senate Inquiry into the "Japanese Aum Sect and Weapons of Mass Destruction". Nunn was reported to have stated that the Senate inquiry team had evidence that the Aum Supreme Truth (Aum Shinrikyo) sect had attempted to purchase nuclear weapons from the Russians and had also attempted to develop same from their own scientific laboratory base—and had probably succeeded. I became worried that, since the 28 May 1993 Goldfields event did have characteristics similar to a nuclear blast, possibly these Aum sect loonies had indeed acquired nuclear weapons and some sort of pulse jet (i.e., Nazi V1 type cruise missile) delivery system.

I contacted Dan Gelber, chief counsel of the US Senate inquiry, and told him of my data and research. His agitated response was: "Please express airpack everything that you have to us asap—at our expense." I complied with his request, and also spoke to him and his assistant several times more on the phone.

I now believe that, although the energies involved in the Banjawarn event were of nuclear-bomb power level, the explosion was not of nuclear but of scalar EM technology origin.

## THE TESLA CONNECTION

In an early telephone call, Dan Gelber informed me that the US had found evidence that in 1992 the Aum sect had sent a research team to study

at the Nikola Tesla Museum in Belgrade, Yugoslavia. Their objective was to get data on Tesla's electromagnetic wave transmission technology, as related to an earthquake-inducing weapons system. Gelber, being a lawyer, did not seem to understand much about this weapons system, but discussed it 'in passing' as evidence for the Aum sect's deep desire to obtain exotic new weapons systems with potential for mass destruction—such as nuclear bombs, nerve gas technology, etc.

Nikola Tesla (1856-1943) was the scientific genius who single-handedly invented modern AC electrical rotating fields and electrical generators, motors, plus radio (Marconi apparently stole Tesla's ideas whilst apprenticed at Tesla's New York laboratory) and a host of other electrical and electromagnetic devices. Most of the foundations of modern 20th century electrical civilisation is due to Tesla's pioneering work in the period 1880-1908.

As it happens, I have a large library of Tesla's works and many books written about him. Tesla's electromagnetics and his understanding of physics have always intrigued me and I have spent many hours pouring over his patents, attempting to visualise the circuits and his understanding.

I was greatly intrigued by Gelber's comments and pondered over their possible significance, if any, to the Banjawarn events of 28 May 1993. I began to reread my Tesla library, searching for any possibly relevant information.



Photo #2 of orange light beam over Fremantle Garden Island Naval Base on 24 May 1990 (© John Goldsmith)

## TELEGEODYNAMICS AND TESLA WAVES

I found references to Tesla constructing a vibrating mechanical oscillator with a perfect periodicity that he used to 'ping' the Earth. He also tried it out on his laboratory building structure and found that when it received a return signal of longitudinal (i.e., scalar) seismic or sound wave energy it added a new impulse "ping" to the return. After a few minutes this wave reinforcement built to such a level that harmonic oscillatory forces created local ground earthquakes and/or began to vibrate the target building to pieces. Tesla built this device to provide a mechanical analogy to his EM wave research and to help him visualise the system dynamics.

Tesla describes taking a sledgehammer to one of his first devices, as this was the only method capable of stopping the rapid collapse of his laboratory and nearby buildings which were all vibrating increasingly violently and in sympathy with the mechanical oscillator's seismic wave packets.

There were vague references in the literature to Tesla's mechanical telegeodynamics theories coupled to suggestions that he could create the same seismic effects with EM "Tesla waves", as produced by his "Magnifying Energy Transmitter"—a giant Tesla coil linked to a special circuit design and a large, spherically shaped 'aerial'.

Tesla utilised these "Tesla waves"—longitudinal (scalar) EM waves (like sound waves) of pure electrostatic potential with no 'E' (electrical) or 'H' (magnetic) transverse vibrational fields. He certainly proved that he could transmit usable electrical energy in very large quantities, without any wires and with only minor energy losses, via his EM Magnifying Energy

Transmitter. He claimed that he was bouncing these Tesla waves through the Earth's core to the antipodes and back to the transmitter (Tx) site. A relatively small, 10 kW-generator energy supply of just a few horsepower would rapidly allow the buildup by resonance of millions of horsepower in the coil circuits of this Magnifying Energy Transmitter device.

Sheets of man-made lightning and blue-white electrical streamers would arc out of the circuit to Earth grounding points, or from the top spherical aerial system. Locals, many miles away from Tesla's Colorado Springs laboratory, complained of experiencing sparks and blue-white streamers of electrical energy issuing from power lines, generators, electric motors, etc., and even from the soles of their boots to the ground.

Tesla had previously demonstrated that fire and flames can be exactly reproduced by very-high-tension, high-frequency, electrostatic potential waves (in fact, that is all a fire is when considered in physics)—dimensions higher than the standard 'burning of, say, carbon in oxygen' philosophy of atomic molecular chemistry.

In his patent for the EM Magnifying Energy Transmitter, Tesla mentions that it can transmit electrostatic potential energy to the planetary antipodes, or create a grid of standing waves and nodes of pure electrostatic potential energy across the entire planet. He provides a method for steering the antipodean target site by utilising two or more waves of differing frequency and amplitude from

two or more widely separated Tx sites.

It is important to realise that he was *not* transmitting standard Hertzian waves which vibrate transversely to the string direction in normal 3D space with a constant rate of time flow—as in standard HF radio transmission. Lord Kelvin of the London Royal Society of Physics once had a serious argument with Tesla at a scientific meeting in New York as Kelvin considered transverse vibrational 'E'- and 'H'-field Hertzian waves to be the only form of EM wave propagation.

However, when invited to Tesla's laboratory, Kelvin was astounded to see by experimental demonstration that Tesla was indeed creating longitudinal vibrational or scalar EM waves of pure electrostatic potential—or, as Tesla called them, *non-Hertzian* radiations. Kelvin then apologised in public and confirmed the existence and nature of the new Tesla wave.

Recent private research in the USA has demonstrated that Tesla waves can propagate in 'n'-dimensional space and may be engineered to operate in a non-linear time dimension at any speed from zero to infinite (not being limited to 'c', the speed of light).

Several Tesla waves sent from different transmitters may also be engineered to combine by interferometry to produce an EM slug of very-high-level infolded or contained energy, with any desired light emission shape, colour and intensity. This slug of EM energy may be moved around the planet at will—visibly or invisibly. The contained energy may be released by a further specific transmission. The EM slug can be moved into the Earth, through the air or into the sea. If 'detonated' in the Earth, an earthquake is the result. In a building or a city, a violent explosion of pseudo nuclear style is the result (even up to nuclear force levels).



Photo #3 of orange light beam over Fremantle Garden Island Naval Base on 24 May 1990 (© John Goldsmith)

## TESLA'S "DEATH RAYS" AND SUPPRESSED EM WEAPONS TECHNOLOGY

In his later years Tesla claimed that he could produce a "death ray", with a range of hundreds of miles, which would be useful against aircraft. Tesla also stated that another of his inventions would allow entire cities to be devastated by explosive EM transmissions across intercontinental distances, to anywhere on the planet, with no defence possible; and that EM "Tesla shields", produced by the same new device, could defend an entire country or a city against aircraft and shells.

He certainly made several public announcements about the "death-ray" and "city-buster" EM weapons systems in the 1920s and 1930s, but no details of techniques have survived in the public domain to my knowledge.

In 1924 a plethora of "death ray" and "anti-aircraft ray" stories appeared in the *New York Times*. The Western Australian *Kalgoorlie Miner* newspaper also published stories on these inventions during the 1920s.

Various inventions were linked to scientists from several nations, e.g., Grindell H. Mathews (UK), Dr T. F. Wall (USA), Herr Wolle (Germany), and Grammachikoff (USSR) (as revealed by belligerent statements by Trotsky). Details of the technology

allegedly employed by these systems are currently unavailable in the Western literature.

An Australian inventor of such a "death-ray" device, Charles Sidney Way, was found dead—shot through the heart under mysterious circumstances—on the promenade of an English seaside resort in late 1937.

News stories were also published in the USA about Tesla's "death ray" inventions in 1924, 1934 and, finally, in 1938.

The 1938 press releases stated that Tesla would employ 50 million volts in a new form of ray wave, only one-hundred-millionth of a centimetre in diameter, based upon an entirely new principle of physics that produced a great repelling force. Tesla stated that this device could melt any engine and that there was no defence against it. It could travel through interstellar space faster than light and, if aimed at the Moon, it would turn a spot on the surface into incandescence.

It would appear that Tesla was referring to something vaguely similar to modern concepts of laser or particle beam weapons, but possibly utilising micro-wave EM transmissions of enormous power, travelling at speeds greater than 'c', the velocity of light. In actual fact, physicists call waves with dimensions of one-hundred-millionth of a centimetre (i.e.,  $10^{-9}$  metres) X-rays, but the size mentioned by Tesla is also quite close to the arbitrary boundary designated for even smaller radiations—defined as gamma rays.

To achieve such wave-packet velocities of greater than 'c' was thought to be impossible in Einsteinian Western physics—until the recent redevelopment of new ideas in physics concerning the theoretical relativistic hyper-space transmission of scalar EM waves—or Tesla waves.

It is also now known that longitudinal scalar EM waves do indeed produce a great repelling force on the atomic nucleus, bypassing the outer electron shells and directly engineering or interfering with the components of the nucleus.

Tesla was not known to make idle statements, but some of his ideas were so incredible and beyond the 'ken' of so many other physics peers that mainstream academics commonly just ignored his work. Only in recent years have some brave souls come out with experimental and theoretical studies that confirm the brilliance of this amazingly practical and innovative mind. Most modern Western university physicists simply ignore Tesla's work. Only Eastern European and Russian universities normally include a study of Tesla's work in their curricula.

As early as 1914, Tesla predicted the electrical control of atmospheric moisture, and he gave some thought to how this 'weather control' could be achieved using his magnifying transmitter. He implied that it would be possible even to affect the Sun's EM fields and output, or certainly modify its effects upon the Earth, by means of EM Tesla wave transmitters.

Tesla suggested a means for lighting the ionosphere by EM waves to produce a dull white glow—to turn night into day and make sea and air navigation safer. This apparently magical thesis would work along the lines of an analogy between the rarefied

upper atmosphere or ionosphere and a standard evacuated fluorescent tube: both can be lit up by a Tesla coil radiating Tesla waves, without any wires having to be used.

Tesla believed that nuclear radiation from specific isotopes, such as radium or uranium, was not just the result of atomic nucleus instability, but that the decay was caused by interaction of the nucleus with a special ray emanating throughout the universe. He stated that it would be possible to engineer EM "shielding" to stop the rays and hence terminate the action of nuclear disintegration, and that therefore, presumably, it would be possible to generate concentrations of such rays and stimulate the nucleus into explosive or rapid general transmutation.

Tesla's radiation and other theories, as well as more recent theoretical studies by US physicist Tom Bearden, have enabled a full elucidation of the reasons for a series of quite bizarre activities associated with the Japanese Aum Supreme Truth sect at Banjarn station, Western Australia, during 1993, and demonstrated the sect's close connection to the Banjarn fireballs, explosion and mini-Tunguska earthquake events.

As research into the "Banjarn Bang" has progressed, an entire collection of bizarre events and coincidences has begun to unravel—but you will have to wait for Part 3 for that...

The next article in this series will cover intelligence on the Japanese Aum sect as regards their interest in EM weapons and their activities in Australia. It will also summarise the known physics and effects of modern scalar EM weapons systems, including their wave-transmission health effects on human and other life-forms, and will detail a variety of recent Earth history events where such weapons are believed to have been employed

by Russian, Japanese and covert US power groups.

#### Note:

Any persons seeing, having seen, or knowing anything about exotic meteor fireballs or other static exotic light emission events, or knowing anything about EM weapons systems technology or deployment and/or testing in Australia or anywhere else on planet Earth, are invited to contribute to this project by telephoning the author on +61 (0)9 525 5999 (after 10.00 am WA time = gmt + 8 hours), faxing on +61 (0)9 525 5944, or emailing on orbitx@ois.com.au.

#### About the Author:

Harry Mason, BSc, MSc, MAIMM, MIMM, FGS, is a UK-born geologist/geophysicist, resident in Perth, Western Australia. His 30-year career in mineral exploration has had him stationed all over the world, including Alaska, India, Norway, Mexico, Morocco, Sudan and UK. He has extensive field experience in geo-recce, geological mapping, geophysics/geochemistry, prospecting, remote-sensing/computer imaging technologies, and seismic and electromagnetic studies. He specialises in the geology and resource exploration of WA's Eastern Goldfields. Lately he has been devoting his time and expertise to researching mysterious Australian outback phenomena of natural and man-made origins.



Photo #4 of orange light beam over Fremantle Garden Island Naval Base on 24 May 1990 (© John Goldsmith)





## CONSTRUCTION OF THE GRAVITO-MAGNETIC DEVICE (GMD)

©1996 by Pierre Sinclair  
Prepared for the 3rd International  
Symposium on New Energy, USA  
April 1996

### ACKNOWLEDGEMENTS

This paper is dedicated to a man whom I respect very much: David Pierre Hamel, a man who helped me tremendously in my quest to understand antigravity and who pushed me to look at science in a new way.

This paper is also dedicated to those who have the time and resources to duplicate the GMD.

### ABSTRACT

In this short paper I would like to convey enough information to help anyone who would like to undertake research into the Gravito-Magnetic Device (GMD). I will give a brief description of the hardware and the theory behind the GMD. I will also talk about various researchers who have come up with very similar theories and results.

### INTRODUCTION

At the end of 1989, I was fortunate to meet a man named David Pierre Hamel. Mr Hamel had been working for the previous 14 years on an energy system that he

claimed could produce antigravity and an abundant amount of energy. Also to support his claim, he said that he had built four prototypes that demonstrated these effects. The first one was built in a 45-gallon drum, the second one was built on a trailer, the third one was built on a plywood base, and the fourth one was built on an eight-foot-diameter platform at 10 feet in the air.

His work paralleled the research that I was doing so I devoted the past six years of research, in collaboration with David Hamel, to understanding the unusual phenomenon and to building a prototype that would demonstrate and conclude that such a technology is obtainable today.

At this time, the GMD is almost complete; so, too are the drawings. This paper will help you understand the basic functions of the GMD. [More detailed information is now available, together with a videotape on how to build, step by step, the model discussed in this paper. The drawing and videotape are available through Project Magnet, Inc. Ed.]

I should note here that all building materials for the GMD are readily available almost anywhere in the world and the cost is relatively cheap. A lot of hand work is required, but nothing that is unattainable. No special machining or parts are required. Only patience and devotion are needed.

Finally, I would like to emphasise that the power generated around the GMD is

extremely strong and it radiates, causing interruptions of electron flow in normal electrical systems, i.e., lights, cars, road transformers and electromagnetic transmissions. So, when completed and activated, this machine must be taken extremely seriously. But don't be alarmed: if a control system is in place, it is easy to stop this effect.

One of the main purposes of the GMD is to understand the effects of enclosed opposing magnetic fields that have varying vector angles—such as in theories set forth by Tom Bearden.

In my opinion, David Hamel has brought about an incredibly powerful and useful technology which also generates antigravity. The GMD has a powerful upward thrust which causes it to rise into the air. Similar work has been done by John Searl of England with his levi-disc experiments. When we understand the inner workings of what causes the secondary electrogravitational fields, the possibility of creating various devices to produce plentiful energy of different types is mind-boggling.

### OVERVIEW OF CONSTRUCTION

It should be noted that the configuration of the parts inside the GMD is such that it promotes an enclosed constant variation of opposing magnetic fields. In the resting state, the moving cones are balanced and stabilised in a magnetic field repulsion, like

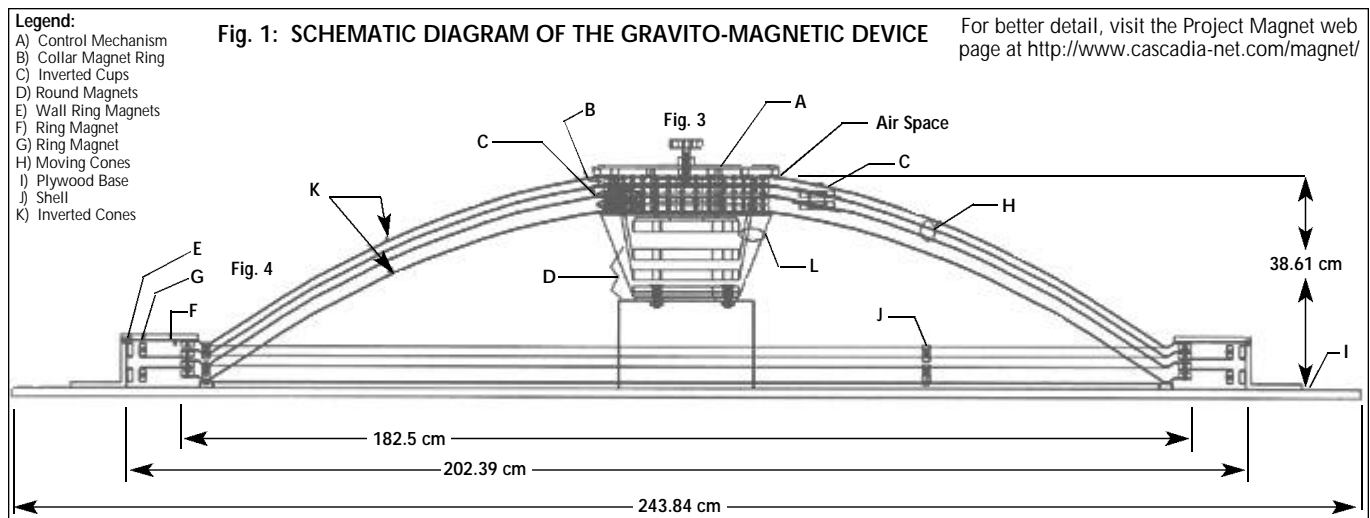
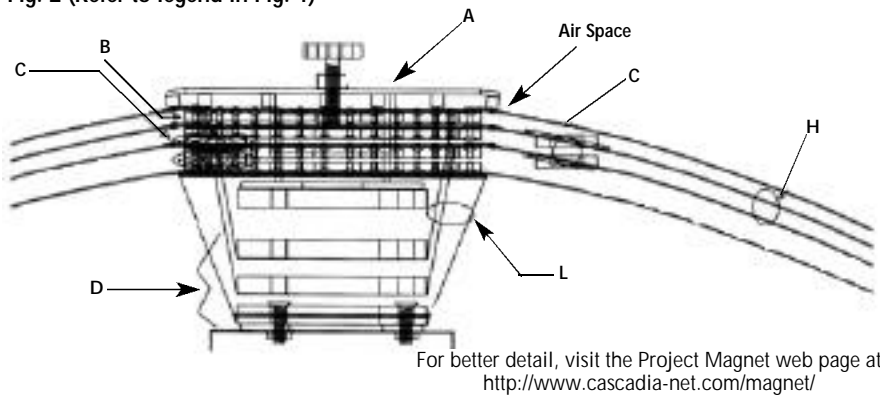

Fig. 2 (Refer to legend in Fig. 1)



a magnetic bearing. This is the hardest part to accomplish.

The start-up of the GMD is initiated by lowering a magnet at the centre top of the shell, inside the shell towards the momentarily magnetically-balanced moving cones. Referring to Fig. 1, as the central magnet, which opposes the one attached at the centre of the upper moving cone, is lowered inside the GMD, it forces the upper cone to move sideways, shifting the magnetic balance between the cones inside the GMD. The cones stay offset to each other for a short while, and then plasma-like energy starts to build up around the GMD. The energy buildup creates a shift of colour from red-orange to light blue and then white. Following this effect, the GMD starts to lose weight and has an upper lift in a greater ratio than its total weight.

The GMD is composed of 12 major components (see Fig. 1): (A) the control mechanism; (B) four individual rings of magnets; (C) inverted cups; (D) three magnets attached to inverted cones; (E) wall rings; (F) outer-edge rings; (G) outer-edge extended ring; (H) moving cones; (I) ply-

wood base; (J) double-sided cones; (K) cone enclosures; and (L) inverted cones.

**A:** In the aluminum casing is the control mechanism. It is composed of a large barium ferrite magnet that is raised or lowered by the use of a corkscrew-type device. The aluminum casing is bolted to the upper body of the GMD. It should be noted that 1/2-inch spacers are utilised to allow for air flow. The magnets used in the control mechanism are identical to all the 'D'-type magnets in Figures 1 and 2.

**B:** Riveted to the collar of each cone is a ring of magnets. Each ring is composed of several individual magnets with all their magnetic poles in the same direction, which creates the desired effect of opposing magnetic fields. The purpose of the configuration of these rings is to minimise the physical weight of the moving cones, 'H'.

**C:** Next to the collar, attached to the wall of the moving cones are three pairs of inverted aluminum cups set 120 degrees apart from each other. The dimensions of all the inverted cups are determined by two factors: (a) the distance between the 'E' and 'G' magnetic rings; and (b) the size of

the ball bearings which fit into the inverted cups.

**D:** Each of the 'D' magnets is attached to a small aluminum inverted cone, 'L', which reaches from the magnet to the collar of the lower 'K' cone and the two 'H' cones. Each of the 'D' magnets, including the magnet inside the control mechanism, 'A', is identical.

**E:** Attached to the wall are two adjustable magnetic rings. The purpose of these rings is to hold the 'H' cones centred and at the tip of the 'J' small double-sided cones.

**F:** Attached to the outer edge of the moving cones 'H' are ring magnets at a 90-degree angle to the 'G' magnets. Their purpose is to support part of the weight of the moving 'H' cones and to generate more opposing magnetic fields. Each cone, 'H' and 'K', has its 'F' magnet aligned in the same polarity.

**G:** Attached at the extreme circumference of the moving cones, 'H', are ring magnets which are perpendicular to the 'G' ring magnet. They repel the field of the magnetic rings around the outer wall, 'E', of the GMD. This is to ensure that the 'H' cones are kept in the centre at a proper distance. The distance between the 'E' and 'G' rings is determined by the strength of each magnet's magnetic field. Here it should be noted that all spacing arrangements are based on magnet field strength.

**H:** The two cones are identical to the 'K' cones except that attached to the outer circumference of each cone is a ring magnet, 'G'. Note that it is important that the attached ring magnet, 'G', is distanced far enough from the 'E' ring magnets so that their magnetic fields do not interfere with each other.

**I:** It is desirable to use plywood as a base, as it is easier to attach, move and remove parts as necessary.

**J:** There are six small double-sided cones that sit in 12 cups. The size and design of the cups allow sideways and wobble movement of the 'H' cones and act as a locking mechanism to restrict the swaying movement of the 'H' cones.

**K:** These two cones are mainly utilised to provide an enclosure, as well as for magnetically clamping the moving 'H' cones.

**L:** The small, inverted aluminum cones are designed to support and attach the 'D' magnets to the lower 'K' cones and the 'H' cones at the collar. It is important to have these cone arrangements to allow an air-flow path between the layers of the cones,

Fig. 3 (Refer to legend in Fig. 1)

For better detail, visit the Project Magnet web page at <http://www.cascadia-net.com/magnet/>

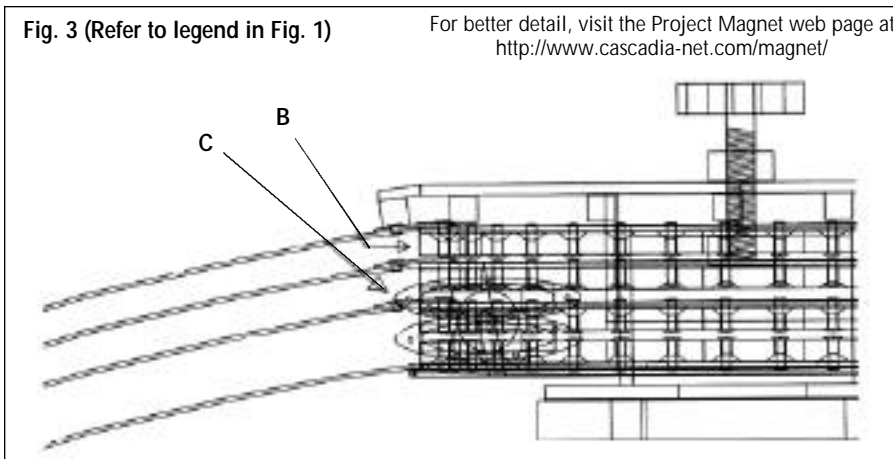

thus triggering the swaying movement of the moving cones, 'H', when the GMD is generating its electrogravitational field.

## EXPERIMENTAL NOTES

So far, the prototype has demonstrated the same mechanical effect that David Hamel claimed. It has shown that when the 'H' cones are manually moved, the air flows in and out of the central hole and the outer edges of the GMD.

Since the control system has not yet been completed and the outer wall not covered [at the time of this presentation], it was not possible for me to tell if the secondary effect showed up around the GMD. But, because all the construction of the different sections of the GMD plus all the mechanical functions have proven to be right, I believe that the secondary effect should show as predicted.

## GENERAL COMMENTS

To my knowledge, there are five people who have come up with devices which use the principle of opposition of magnetic fields at vector angles—devices which demonstrate unusual and similar effects to the David Hamel devices:

- **John Searl**, with his levi-disc machine.
- **John Hutchison**, who has demonstrated the opposing magnetic field using Tesla coils with varying frequencies.
- **W. J. Hooper**, whose test apparatus, employing an enclosed, shielded metal can, utilised an electromagnetic coil wound in such a way that each electromagnetic field

Fig. 4 (Refer to legend in Fig. 1)

For better detail, visit the Project Magnet web page at <http://www.cascadia-net.com/magnet/>

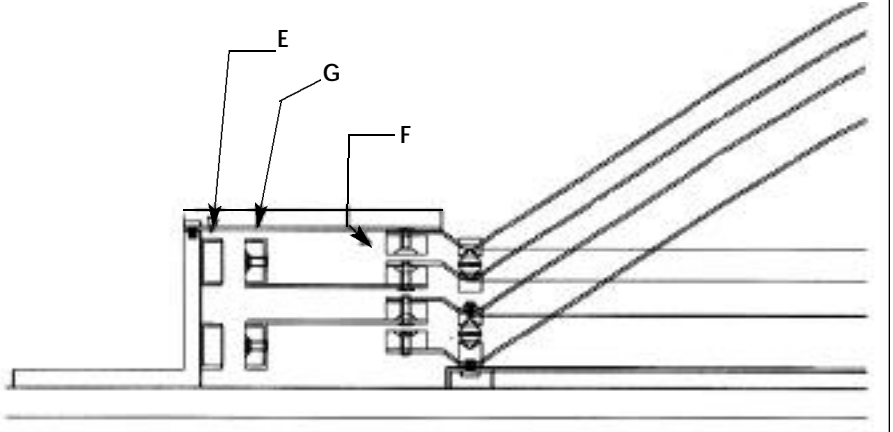

would oppose each other. He showed a direct relation with the field strength inside the can and the electric field appearing outside the can.

- **Floyd Sweet**, who made several devices proving that stressing a magnet with an opposing magnetic field would cause the magnet to generate a secondary field in the surrounding space which could then be trapped with scalar-wound coils.

- **Wilbert Smith**, who demonstrated that using electromagnetic coils wound in the same fashion as Hooper's, but with two overlapping coils of the same, would also produce unusual effects.

- **Tom Bearden**, who, in my opinion, has advanced the best theory to explain the reasons for the unusual behaviour of this energy. He also explains what causes this reaction at the nuclear level.

## About the Author:

Scientific researcher Pierre Sinclair, from Fort Langley, British Columbia, Canada, has devoted years to advanced research into alternative sources of energy. His work has drawn the attention of various groups who commissioned him to build prototypes and experiment with these sources of energy.

Pierre Sinclair's research focus over the last six years has been on David Pierre Hamel's theories and devices. In collaboration with Hamel, he is now close to completing a duplicate of one of four prototypes that demonstrated antigravity and other unusual effects when tested at Maple Ridge, BC, Canada.

Pierre Sinclair can be contacted by e-mail on: [magnet@smarrt.com](mailto:magnet@smarrt.com)

Fig. 5 (Refer to legend in Fig. 1)

For better detail, visit the Project Magnet web page at <http://www.cascadia-net.com/magnet/>

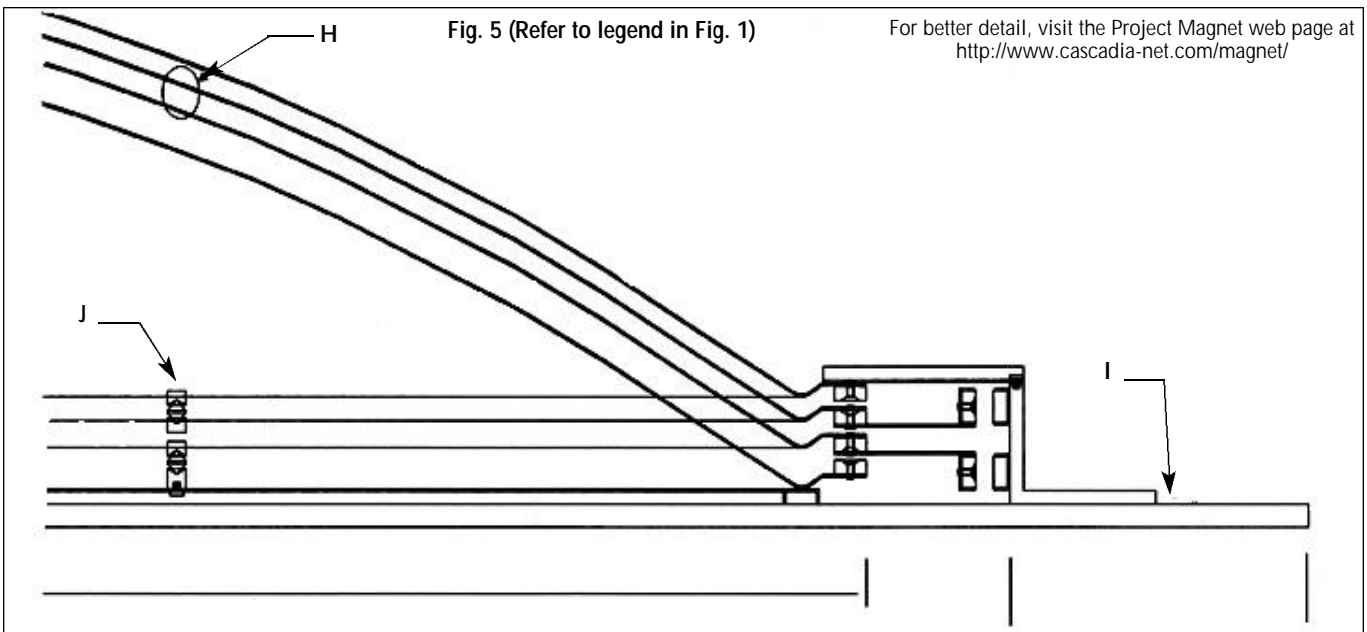



# The Secret Lives of Francis Bacon

*Sir Francis Bacon had many reasons for passing off some of his own great literary work under the pen-name of William Shakespeare.*

by Michael Taylor ©1996

Excerpted from his book  
**Master R: Lord of Our Civilisation**  
Published by The Rawley Trust  
PO Box 2831, Christchurch 8015  
New Zealand  
Telephone: +64 3 366 2943  
E-mail: Mike.Taylor@netaccess.co.nz

## MASTER R: THE MASTER OF THE ROSE

**R**osicrucian, Theosophical and New Age writings over the last century have discussed a master soul, known as the Master R., who has incarnated many times to give guidance to the emergence of Western society. These writings also discuss a hidden spiritual hierarchy on or involved with this planet. This hierarchy has seven so-called "Ray Lords", each of whom rules over an aspect of life that is defined by each ray.

The Lord of the 6th Ray was Jesus Christ—the avatar (spiritual leader) of the age of Pisces. The 6th Ray's characteristics include devotion and idealism, central tenets of Christianity. The Lord of the 7th Ray is said to be the Master R. The 7th Ray is the ray of transmutation, synthesis and purification—or alchemy. It is the ruling ray for the Aquarian age which we are now entering. It is interesting to note that Jesus Christ prophesied the coming of the "water-bearer" (Aquarius) at the Last Supper. He told his disciples to go into the city where they would meet a man with a pitcher of water, and that they should follow this man.

The Lords of the Seven Rays appear in Hindu mythology, except they are called avatars—manifestations of gods in human form. Here we approach the crux of the Ray Lords mythology. In Hindu mythology there are 10 avatar incarnations in each cycle of existence, each one 2,000 years apart. The avatar of the Arian age was represented by Abraham (meaning "I am Brahma"), who embodied the Brahma aspect of the Hindu trinity. The Brahma aspect symbolises being and willpower. The next avatar was symbolised by the fish—the symbol of Christ and the age of Pisces. Following on from this is the boar avatar—the symbol of the Master R. and the age of Aquarius. The next avatar, symbolised by the turtle, will appear 2,000 years hence, according to the mythology.

In Hindu myth, the boar avatar manifests the Vishnu, or wisdom, aspect of the Hindu holy trinity. The age of Aquarius is the age of the mind, of wisdom, and Aquarius, of course, is an air sign. The avatar of the Aquarian age is also known as John, equated with the Christian John the Beloved and the Master R.

Not only do the Hindu and Christian religions foretell the coming of a master for the Aquarian age, but other signs have manifested themselves.

The alchemist Paracelsus (1493-1541) foretold the coming of the Master R. after observing the supernova in the constellation of Cassiopeia in 1572-74. He saw it as:

*...the Sign and Harbinger of the approaching revolution: there is nothing concealed which shall not be revealed, for which cause a marvellous Being (Elias the Artist) shall come after me, who as yet lives not, and who shall reveal many things.*

One of the greatest incarnations of the Master R. was as Sir Francis Bacon (1561-1626?), who was Lord Chancellor of England from 1618 to 1621. That Bacon was the Master of the Rose is made clear by his family symbol, the boar. Bacon is also regarded as the father of the Rosicrucian secret society.

That this "Elias the Artist", mentioned by Paracelsus, was Francis Bacon is clear from Rosicrucian writings:

*Elias Artista! Genius Director of the Rose Cross, symbolical personification of the Order... Paracelsus the Great has predicted thy coming...*

In his *Mathematical Magick*, Dr Wilkins of the Royal Society referred to the "Director of the Rose Cross" as "Francis Rosicross". Wilkins was the first secretary of the Royal Society, the original idea for which came from Bacon.

By looking at Francis Bacon's life we can understand the long-term goals and plans of the Master of the Rose, which even now are still coming to fruition.

## FRANCIS BACON: MASTER OF THE PROSE

Elizabethan England was anything but a free society. As in continental Europe at the time, the authority of the monarchies and the Church was undisputed. Sovereigns held the power of life or death over their subjects. Authorities encouraged informers—spies—to hand in heretics and political radicals, who were then tortured into confessions before being executed. England was in the midst of a theological split between Catholicism and Protestantism. Its coming Renaissance was but a flicker in the minds of a tiny, learned elite.

Amidst this unstable background, Elizabeth I came to the throne in 1558. By the time Charles I succeeded to the throne in 1625, the English language had been transformed and English commerce and trade led the world. America was being colonised, and foundations had been laid for a revolution in political thought and science.

As W. T. Smedley, a biographer of Francis Bacon, stated:

*From 1576 to 1623...the English language was made...the finest examples of its capacities which today exist. But the knowledge and wisdom possessed by the classical writers, the histories of the principal nations of the world, practically everything that was worth knowing in the literature of other countries, were for the first time made available in the English tongue...<sup>1</sup>*

But this remarkable English Renaissance was not a spontaneous happening—not much in history ever is. It was the deliberate design of a small group, led by Sir Francis Bacon. Bacon called his plan "The Great Instauration" for the "worldwide reformation of the arts and sciences". This plan was the result of a vision he received in his youth—a vision of a world transformed by science and reason.

During his youth, Bacon had stayed for three years with the French court where he mixed with a group of philosophers, "the *Pléiade*", labouring to bring about a revolution in thought in France. Inspired by their efforts to reform the French language and set learning at the pinnacle of human endeavour, he applied a similar program in England but on a grander scale.

Bacon was a visionary in every sense of the word. His writings covered every conceivable area of human endeavour from science to romance, from politics to the use of ciphers; but his method of dissemination was unusual, though not unusual for the times in which he lived. Bacon partially revealed his method in his works,

*Novum Organum and The Advancement of Learning:*

*Now for my plan of publication; it is this. Those parts of the work which have it for their object to find out...such minds as are prepared and disposed for the argument, and to purge the floor of men's understandings, I wish to be published to the world and circulate from mouth to mouth; the rest I would have passed from hand to hand with selection and judgment...a sound foresight, which tells me that the formula itself of interpretation, and the discoveries made by the same, will thrive better if committed to the charge of some fit and selected minds, and kept private.<sup>2</sup>*



## BACON'S CIPHERS AND PEN-NAMES

So, Francis Bacon kept much of his works 'hidden' from the public by using both ciphers and pen-names. Many historians make reference to the abovementioned passage and conclude that Bacon never finished his publishing plan. But there is much evidence to indicate he used pen-names to conceal his literary output.

A clue to the greatest of his pen-names is given by Anthony Bacon, Francis' foster-brother. In a sonnet Anthony wrote in 1595-96, he stated that Francis Bacon's muse was the goddess Pallas Athena—the *shaker of the spear* of knowledge at the serpent of ignorance writhing at her feet. The sonnet read:

*Therefore Bacon, if it chances that my Muse praises someone  
It is not because she is eloquent or learned,  
Although your Pallas has taught me better (how to speak);  
It is because my Lute sings the saintly glory  
Or in these artless lines (naïve) his image is imprinted  
Or that thy Virtue bright shines in my shade.<sup>3</sup>*

Even one of Bacon's titles, Lord Verulam, translates as "Spearshaker".

Bacon's use of pen-names and the ciphers within his writings have been extensively written about for over a century.<sup>4</sup> Ciphers run through all of Bacon's works, regardless of pen-name, from the *Shepherds Calendar*, published in 1579, to the *First Folio*, published in 1623. It is more commonly thought that Edmund Spenser was the author, but he could not have been as he was only 11 years old when *Shepherds Calendar* was first published. The first editions of that work were published anonymously. Indeed, most people of any importance at the time wrote in cipher in order

to protect themselves. Bacon was in more need than most of protection, as his secret parentage was of extraordinary importance to the future of Britain. Bacon used many different cipher systems to record details of Elizabethan England and his life which he could not utter publicly.

The ciphers tell the real story of the authorship of the Shakespeare plays. For instance, the first message of the 6th line word cipher in Shakespeare's *First Folio* states:

*Bacon—a strange beginning—this hath some seeming—first to show the name—I find tis wonderful I perform for you...Dos't though not perceive—you may aske—I am Bacon.*

This message from the word cipher in Shakespeare's *First Folio* is also revealing. It states in part (with Queen Elizabeth I speaking to Bacon):

*How now, thou cold-blooded slave, wilt thou forsake thy mother and chase her honour up and down? Cursed be the time of thy nativity... I am thy mother...*

That Bacon used the name of an illiterate actor from Stratford—William Shak-spur—and changed the name to echo his muse exactly, becomes clear in the ciphers of Bacon's plays. The ciphers are vast, stretching over 56 years, tens of thousands of pages, numerous editions and many different systems. Some of the cipher messages are still waiting to be discovered.

Bacon, with the aid of his "Rosicross" literary fraternity, changed the shape of the English language, invented over 10,000 new words and planted his thoughts and phrases in the minds of every man and woman in the Western world. Yet this was only part of Bacon's contribution to the development of the modern world.

### BACON'S ROYAL BIRTH

In Dr William Rawley's *Resuscitatio* (1670 edition) was published a Bacon work, entitled "In Happy Memorie of Elizabeth, Queen of England". Bacon wrote:

*Childless she was and left no issue behind her, which was the case of Alexander the Great, Julius Caesar, Trajan and others.*

In fact, all these rulers did have children, but their children were not recognised as successors to the throne. So Bacon was saying that the Queen had a child or children who could not succeed to the throne—but who?

Pierre Amboise, in his book, *Life of M. Francis Bacon, Chancellor of England* (1631), stated that Bacon was "born in the purple". According to a law passed in 1464, commoners were not permitted to wear purple, the colour of royalty. When Bacon married in 1606, he was clad from top to toe in purple. Bacon wasn't a commoner, but born of royal blood. Amboise went on to write that Bacon was "destined one day to hold in his hands the helm of the Kingdom". There was no way he could hold the reins of the Kingdom unless Bacon was Elizabeth's son and destined to be Francis I.

Foreign ambassadors, writing in cipher to their sovereigns, reported the Queen's pregnancy in 1560. According to Madame Deventer von Kunow in the book, *Last of the Tudors*, a secret despatch among the escorial papers reported that the Queen was

expecting a child by Lord (Robert) Dudley, Keeper of the Queen's Horse.<sup>5</sup>

Sir Nicholas Throckmorton, Elizabeth's Ambassador in France, wrote to Sir William Cecil on 31 December 1560, stating that the Spanish Ambassador had just visited him, who did "earnestly enquire me to tell him whether the Queen's Majesty was not secretly married to Lord Robert; for, said he, I assure you, this [the French] court is very full of it, and the rumours of her doings be very strange in all courts and countries".<sup>6</sup>

On her succession, Elizabeth made Dudley Master of the Queen's Horse. He was given rooms interconnecting with the Queen's and access at all times to the Queen's chambers. By April 1559, their affection for each other was public.

Count de Feria, the Spanish Ambassador, reported to Philip II of Spain that, "During the last few days Lord Robert has come so much into favour that he does what he likes with affairs, and it is even said that Her Majesty visits him in his chamber day and night."<sup>7</sup>

Soon afterwards, Dudley's wife, Amy, fell down the stairs at her home and died. According to the word cipher in Shakespeare's *First Folio*, soon after Amy's death Elizabeth and Dudley went to Baynards Castle, the London townhouse of Lord Pembroke, a

member of the Privy Council, where they were secretly married. Sir Nicholas Bacon, Lord Keeper of the Great Seal, performed the ceremony, which was observed by Sir Nicholas' wife, Lady (Anne) Bacon.

Francis Bacon was born on 22 January 1561, and taken into the care of Sir Nicholas and Lady Bacon.

### THE GROUNDWORK IS LAID

Sir Nicholas provided Francis with the best education England

could provide at the time. Surrounded by learned men and learned works, Bacon's home tutoring was unsurpassed in those times. His education at Trinity College, Cambridge, was an anticlimax in comparison.

At age 12, Francis Bacon had a powerful vision which showed him a future based on rationality and science, where philosophy was put to practical use rather than pedantic argument. Inspired by this divine vision, Francis embarked on the "worldwide reformation of the arts and sciences"—"the Great Instauration" (*Magna Instauration*, published in 1620). Bacon articulated this in the proem to *The Interpretation of Nature* (written in 1603, but not published until 1734):

*But when I searched, I found no work so meritorious as the discovery and development of the arts and inventions that tend to civilise the life of man...Above all, if any man could succeed, not merely in bringing to light some one particular invention, however useful, but in kindling in nature a luminary which would, at its first rising, shed some light on the present limits and borders of human discoveries, and which afterwards, as it rose still higher, would reveal and bring into clear view every nook and cranny of darkness, it seemed to me that such a discoverer would deserve to be called the true Extender of the Kingdom of Man over the universe, the Champion of Human Liberty, and the Exterminator of the necessities that now keep men in bondage.*

From 1576 to 1579 Francis stayed with the French court where

Even one of Bacon's titles, Lord Verulam, translates as "Spearshaker".

he was influenced by the *Pléiade* philosophers, led by Ronsard. They acquainted Bacon with the various traditions such as the Egyptian mysteries, Gnosticism and the Knights Templars. The *Pléiade* opened Bacon's mind to the secrets and history of the Western mystery tradition, thus influencing his later plans and work.

Bacon's subsequent political career in the Elizabethan Parliament and under James I seems a mere sideshow to the vast philosophical undertaking he had set himself. Even so, he represented many constituencies, notably the foremost seat of Middlesex, and later, simultaneously, St Albans, Ipswich and Cambridge. Francis Bacon is the only person in history to have been a member of the House of Lords and the House of Commons at the same time. In Parliament he served on no less than 29 committees and was regarded as one of the most eloquent orators ever to have stood before the House of Commons.

Yet Bacon saw that omnipotent government was not the answer: "The truth can never be reached by listening to the voice of authority," he wrote. He opposed subsidies for business and government-granted monopolies. In 1589 Bacon moved that a subsidy bill (a taxation bill) to give monies to the Queen be extraordinary; in other words, be meant for war only. The amendment was passed, establishing the base for the eventual ascendancy of Parliament over the Crown.

In 1593, under the threat of imprisonment by Elizabeth, Bacon again spoke against the Crown's encroachment on the right of the House of Commons to set taxation levels. Bacon believed the amount requested would press heavily on the poor and that many would not be able to pay it. Bacon won against the Crown, and secured freedom of speech for the English in their own Parliament and the right of the Commons to set the amount of supply to the Crown. This set the tone for future democracies that adopted the Westminster system of government.

Bacon spoke against feudal privileges and opposed the enclosure of common lands by landowners. He also proposed to alter the language of the laws to make them accessible to the common man. Bacon, himself trained as a lawyer, said in Parliament:

*Laws are made to guard the rights of the people, not to feed lawyers.*

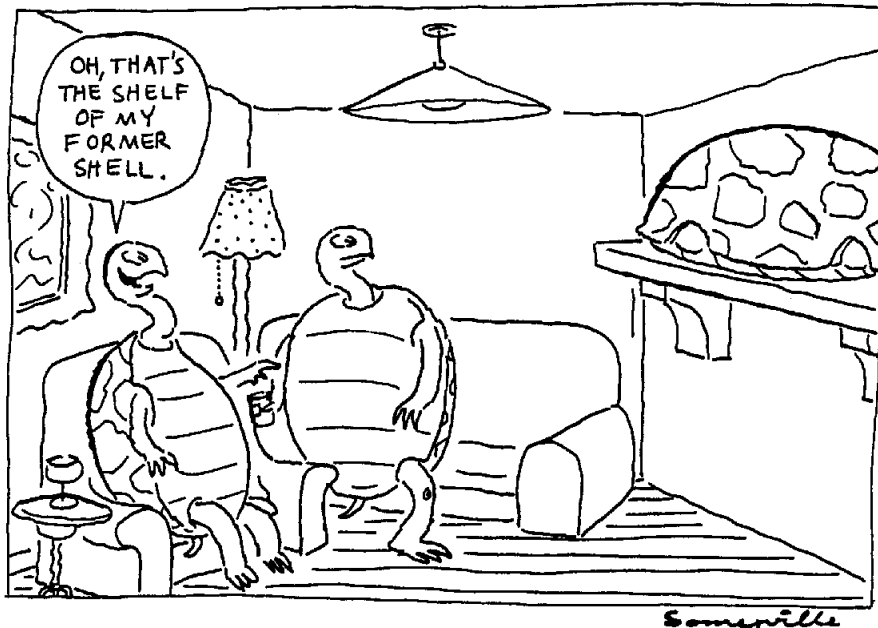

Francis Bacon fought in Parliament for union with the Scots to increase England's strength against threats from the continent. This eventuated under James I and finally put an end to threats of instability to the north of England.

Bacon also pushed for expansion of colonisation in America, notably Newfoundland and Virginia, and donated much time and money to establishing those colonies. He was respected by all mainly for his virtue, but held in jealousy by his enemies, like the hunchback Robert Cecil who knew the secret of Bacon's birth and desired to keep him down.

Under James I, Bacon was knighted in 1603, appointed Solicitor-General in 1606, and achieved the post of Attorney-General in 1613. In 1618 he became Lord Chancellor of England—the highest government post in the land next to the Crown.

### THE FALL FROM GRACE

In 1621, Francis Bacon fell from public office after being framed by Edward Coke, his parliamentary colleague and nemesis from Elizabethan times.

Coke, the Leader of the House of Commons, was determined to find evidence to indict Bacon and bring about his downfall. Others were involved in the conspiracy, including the cleric Dean Williams who coveted Bacon's post as Lord Chancellor.

In 1621 Dean Williams had an audience with the King, where he advised James I to make Bacon a scapegoat to divert attention from James's abuses of monopoly patents.

Shortly thereafter in Parliament, Coke, a friend of Williams, charged that the Lord Chancellor was suspected of bribery and corruption—for accepting considerable monetary bribes in exchange for favourable verdicts in court. It was alleged that Bacon had made hundreds of thousands of pounds in this manner.

Initially considering the charges to be a joke, Francis Bacon soon realised the seriousness of the situation. He started vigorous preparations for his defence.

On 24 April, however, the Lord Chancellor admitted guilt to the charges, although he had never seen these charges and didn't know how many there were. On 3 May the House of Lords pronounced its verdict. Bacon was ordered to pay a huge fine, was stripped of office and was sentenced to the Tower of London.

Francis Bacon was bound by oath to obey his monarch, and James I had ordered him to confess to the charges in order to protect himself (the King) and James's favourite courtier, Buckingham, from their abuse of the monopoly patents. This fact was discovered in Dean Williams' private papers, uncovered many years afterwards by Bushell, Francis Bacon's confidential secretary. It should also be remembered that the charges never went to trial; nothing was ever proved against Bacon.<sup>8</sup>

James I pardoned his sentence that year, and Bacon returned to his country estate, Gorhambury, to complete his secret literary work.

### BACON'S 'DEATH'

The accepted history is that Bacon died on Easter Sunday, Resurrection Day, 1626, after coming down with a chill, but there are so many inconsistencies in the story that



even Bacon biographer Parker Woodward, a solicitor, called the death a "spoof".

Bacon was at Highgate with Dr John Wedderburn, the King's physician no less, when he came down with a chill. Wedderburn took Francis to the empty Highgate House and placed him in a *damp* bed. That the King's physician did this is beyond belief. A few days later, on Easter Sunday, Bacon reportedly died.

However, there is anecdotal evidence, in the last words of Bacon's sonnet diary, hinting at his real fate:

*You shall hear the surly sullen bell  
Give warning to the World that I am fled  
From this vile World with vilest Worms...to dwell.*

In the 1671 edition of *Resuscitatio*, Molloy stated:  
*Bacon made a holy and humble retreat into the cool shades  
of rest, where he remained triumphant above fate and fortune  
till heaven was pleased to summon him to a more triumphant  
rest.*

Henry Oakley of Trinity College wrote of Bacon:  
*He is gone, he is gone. The Word suffices. That he is dead  
we say not.*<sup>9</sup>

Bacon was allegedly buried in a tomb at St Michael's Church, St Albans, but when the tomb was opened 100 years later nothing was found: no bones, no valuables, not even a coffin. There is no mention of his funeral in contemporary records, nor is there any item for funeral expenses in the accounts of the administrators of the estate. There is also no record of his burial in the registers of St Michael's. Given Bacon's prestige and former high standing, it is remarkable there is no record of anyone even attending his funeral.

Manly Hall, the American Masonic writer, claimed that Bacon faked his own death and fled to the continent to continue his work strengthening the Freemasonic lodge system. Probably residing in Germany, Bacon may have been the mystery publisher of Rosicrucian literary works.

One Rosicrucian painting indicates an association between continental Rosicrucian history and Francis Bacon. This painting is from the archives of Frau le Coq, wife of the late Professor Von le Coq, of Berlin University, who was an expert in Rosicrucian history. It shows Bacon as an old man, but clearly shows his initials, "F" and "B", on two of the crests.

Not only may Francis Bacon have spent more years on the continent after 1626; he may also have visited America. And it is in the New World—in Williamsburg, Virginia—where a still more remarkable mystery is waiting to be solved.

## THE BRUTON CHURCH VAULT

Bacon was a master of the treasure hunt, leaving clues for future ages so the truth could be revealed. Discovering his ciphers has been part of the treasure hunt, but these same ciphers point to another remarkable mystery.

In Williamsburg, Virginia, is the Bruton Parish Church. Buried in the grounds is a vault reportedly containing Bacon's writings—

philosophical, historical and literary treasures, all waiting to be rediscovered. The ciphers which give the exact location of the vault are recorded on the title page of Bacon's *The New Atlantis*, and on various tombs in the Bruton churchyard itself. For instance, the cipher on the Ludwell tomb states:

*Under the secret foundations of former Bruton lies Francis  
Bacon's Great Virginia Vault of Freemasonry.*

There have been several attempts this century to dig up the vault and disclose its contents, but each attempt has been frustrated by the Church owners who refuse to cooperate with the controversial Baconians. It is only a matter of time before the vault is uncovered. What is inside is a matter of conjecture. Given Bacon's literary achievements, it is likely to be a remarkable discovery.

## BACON'S LEGACY

Bacon's method for permeating his philosophical ideas into the collective unconscious of the age can best be summarised in his motto: *Bene visit qui bene latuit* (One lives best by the hidden life). He used secret societies to infuse his ideas into the mainstream of society. Bacon resurrected the Rosicrucian mystery tradition and the actual organisation of the Freemasons, injecting new life into them so that they became vehicles for the new Baconian philosophy of reason and scientific enquiry.

Bacon, like Goethe, scorned knowledge that did not lead to positive action and also scorned the denial of evil in ourselves.

Bacon was grateful to Machiavelli for his frank appraisal of the shadowy side of human nature in politics:

*We are beholden to  
Machiavelli, and writers of that  
kind, who openly and unmasked  
declare what men do in fact,  
and not what they ought to do;  
for it is impossible to join the  
wisdom of the serpent and the  
innocence of the dove, without  
the precious knowledge of the  
nature of evil.*<sup>10</sup>

Bacon's works touch on all aspects of humanity—politics, religion, theology, scientific method—but his most brilliant observations are psychological. Foreshadowing

the discoveries by Carl Jung about the nature of the unconscious and the shadowy side of man, Bacon realised that the baseness of man should be recognised and dealt with openly, rather than repressed and personified as the devil.

In modern political vernacular, Bacon was a conservative. He saw an ideal government as one which was benevolent without the worst excesses of despotism by rulers or by the majority:

*It is almost without instance that any government was  
unprosperous under learned governors.*<sup>11</sup>

Bacon had a goal to be that governor, a philosopher-king, as Francis I of England—until Elizabeth's death ended this dream.

In science, Bacon sought nothing less than the construction of a system that could be applied to the relief of man's suffering. He constructed a new "Classification of Science" (*The Advancement of Learning*, 1605) and described a new "Method for the Interpretation of Nature" (*Things Thought and Seen*, 1607; *Thread of the Labyrinth*, 1606; *Novum Organum*, 1608). He investigated the phenomena of Nature in *Natural History* (1622), and showed how the writers of the past had advanced their truths to the time of

**Francis Bacon is the only person in history to have been a member of the House of Lords and the House of Commons at the same time. In Parliament he served on no less than 29 committees...**

Bacon in *Forest of Forests*, published in 1624. Bacon recorded "anticipations" of scientific results he felt would come from application of his methods in *On Origins* (1621). He described in *The New Atlantis* (1624) the basis of a new society that would emerge as a result of applying these principles.

*Magna Instauratio* (the Great Reconstruction) was inspired by the vision Bacon had in his youth, and was an Herculean task without precedent in the history of thought. As Bacon stated in the preface to *Magna Instauratio*:

*...and I...am labouring to lay the foundation not of any sect or doctrine, but of utility and power... Knowledge is power, not mere argument or ornament.*

In *The Advancement of Learning*, Bacon suggested that all areas of life—medicine, psychology, even dreams, predictions and other occult phenomena—had rational rules and an empirical basis, yet he went full circle at the end of this survey, concluding that science needs to be guided by philosophy. Bacon applied this to politics, for he saw that the pursuit of politics becomes a destructive bedlam when divorced from science and philosophy, or, in other words, from rationality and higher goals.

So Bacon suggested the organisation of science itself, of communication between centres of learning to share research and resources, and of royal patronage of the sciences. As a direct result, the Royal Society was later formed, with the financial support of the Crown.

*Novum Organum* represents the summit of Francis Bacon's open works. It introduced a new method of logic to learning, to replace the old ways which had borne so little fruit.

Bacon pointed to errors in thought that had to be corrected in order for humanity to advance. Firstly, Bacon said that experience of the world should have primacy, not the realities or misconceptions held in the minds of men, and that observation should be the cornerstone of scientific method. Secondly, he observed that different people look at the same experience in different ways, filtering reality to suit their present state without seeing what is really there. Thirdly, Bacon saw the inappropriate and careless use of language as an enemy to true understanding. Lastly, Bacon saw errors in looking at the world through the eyes of other philosophers.

Francis Bacon went on to explain the scientific method of enquiry: that of experimentation and observation. He noted that by accumulating data one can arrive at the form or essence of a phenomenon.

The modern secular age of science was foreshadowed in *The New Atlantis*, the story of an island utopia in the Pacific where science prevailed over ignorance and superstition in all spheres of human life. Politically, the island had no elections, no ruler; just a learned council of men who had proven themselves by scientific achievement; in other words, a government without politicians. Most of the time these 'rulers' were engaged in trying to control Nature rather than their fellow man.

## THE FUTURE OF LIBERTY

Bacon effectively laid the foundation for a new age of secular wisdom. When the Royal Society was formed in 1662, the

founders named Bacon as their model and inspiration. The great minds of the French Enlightenment dedicated their masterpiece, *Cyclopédie*, to Francis Bacon.

The French Enlightenment philosopher Diderot (1713-1784) said of Bacon:

*That extraordinary genius, when it was impossible to write a history of what was known, wrote one of what it was necessary to learn.*

Will Durant stated in *The Story of Philosophy*:

*The whole tenor and career of British thought have followed the philosophy of Bacon. The inductive method...gave John Locke the idea of an empirical psychology, bound by observation and freed from theology and metaphysics; and his emphasis on "commodities" and "fruits" found formulation in [Jeremy] Bentham's identification of the useful and the good.*<sup>12</sup>

The political reformer Edmund Burke was also greatly influenced by the Lord Chancellor:

*Genius the most profound, of literature the most extensive, of discovery the most penetrating, of observation of human life the most distinguished and refined.*<sup>13</sup>

**Under the pen-name Shakespeare, Bacon had the most significant effect on English literature of any single person in history.**

Thomas Jefferson was also profoundly influenced by Bacon's writings. Jefferson thought that in his founding the United States he was fulfilling Bacon's dreams as summarised in *The New Atlantis*.

Biographer Hepworth Dixon summarised the contribution that Bacon's open works have made to our world:

*The obligations of the world to Francis Bacon are of a kind that cannot be overlooked. Every man who rides in a train, who sends a telegram, who follows a steam plough, who sits in an easy chair, who crosses the channel or the*

*Atlantic, who eats a good dinner, who enjoys a beautiful garden, or undergoes a painless surgical operation, owes him something.*

*...the patriot, the statesman, the law reformer, the scientific jurist, the historian, the collector of anecdote, the lover of good wit, of humorous wisdom and of noble writing, also owes him something.*<sup>14</sup>

A guiding spirit behind the schemes of Raleigh and others to set fledgling colonies on an untamed continent, Francis Bacon was tireless in lobbying the King and his fellow countrymen to explore and colonise America.

Under the pen-name Shakespeare, Bacon had the most significant effect on English literature of any single person in history. He literally recreated the entire English language and wrote arguably the greatest literary works of the Western world.

It is without precedent that one man could achieve so much in one life, but Francis Bacon can be credited with laying the groundwork for our modern age of reason, science and liberty in the West.

Continued on page 84







**REPORT ON THE CSETI  
BRIEFINGS  
Washington, DC, USA  
7-11 April 1997**

by Steven M. Greer, M.D. ©1997

**BACKGROUND**

**C**SETI [Center for the Study of Extraterrestrial Intelligence] founded *Project Starlight* over three and a half years ago as an initiative to identify the best scientific evidence related to UFOs and extraterrestrial intelligence. Of particular importance is the identification of bona-fide military, intelligence, government contractor and other government agency employees with direct, first-hand knowledge of the UFO/ET subject.

The goal of the CSETI *Project Starlight* initiative is to present the best available evidence and witness testimony in a manner which would constitute a definitive disclosure regarding the reality of the UFO/ET subject. This is to be done in a scientific, non-sensational and hopeful manner, assiduously avoiding an alarmist tone or emphasis.

Since 1993, Dr Steven Greer, CSETI Director, and other CSETI *Project Starlight* team members have provided preliminary briefings for White House staff, a sitting Director of Central Intelligence, senior military leaders, senior United

Nations leadership, members of the Senate and House of Representatives, international leaders and leaders in foreign governments, among others.

It has always been our intent to effect this disclosure in cooperation with the United States and other governments, if possible. We are acutely aware of the vast and profound implications of this matter and for this reason have carefully included key government figures and offices in our deliberations and plans. From the start, it was made clear that, while we desired a cooperative effort leading towards disclosure, the matter would be disclosed through a civilian-led initiative should the government choose to be uninvolved.

Through exhaustive and repeated private briefings with various government leaders, we learned that this subject was being managed in a way which kept the majority of our constitutional leadership uninformed on the subject. It became clear that we should collect the best evidence and witnesses and provide unmistakable and unambiguous information to these leaders so that they could make a decision on how to proceed. Obviously, unless the leadership was informed, there could be no chance of their disclosing any information to the public, or even of convening an open hearing and inquiry.

On 15 November 1997, a letter was sent

to all pertinent offices of the United States Government asking for a determination on the validity of national security oaths related to the UFO/extraterrestrial subject. In this letter, which is available on the CSETI website ([www.cseti.org](http://www.cseti.org)), it was stated that it was our assessment that these oaths and restrictions were null and void, since the oversight of the projects related to this subject was improper, illegal and extra-constitutional. [See Manifesto in NEXUS 4/02.]

Further, it was stated that, unless otherwise directed by 1 January 1997, we would regard all military, intelligence and other government-related witnesses to UFO/extraterrestrial projects and events as free to speak openly about what they know concerning this topic.

No corrective measures or statements—oral, written or otherwise—were submitted to us by 1 January 1997. Through back-door channels it was conveyed that we would be allowed to move forward, and that our progress was being noted by various military, intelligence, government and private groups connected to the subject.

Pursuant to the above letter, since no instructions stating otherwise were sent by the US Government, CSETI proceeded to plan a Washington, DC, Briefing for this spring, as promised.

During the week of 7-11 April, the CSETI *Project Starlight* team convened a

# THE TWILIGHT ZONE

gathering of nearly 20 first-hand government witnesses to UFO/ET events. These gatherings principally took place at the Westin Hotel in Washington, DC, although separate briefings took place at the Pentagon and elsewhere in the Washington vicinity.

All of the US Government witnesses who were present signed a statement that they are willing to testify under oath before an open hearing in the US Congress concerning the UFO/ET projects and events which they personally and directly witnessed. These government UFO witnesses spanned from the early 1950s to the 1990s, and represented events and/or projects observed while these witnesses were in the Air Force, Army, Navy, NASA, private industry and intelligence operations. Most of these witnesses had top secret clearances and were testifying regarding events which took place while they had those clearances.

It should be noted that the witnesses who were assembled during the week of 7-11 April are the courageous tip of a much larger iceberg. There are 107 such first-hand government UFO witnesses who have been identified to date, and who should be subpoenaed by the Congress to testify in open hearings. Conceptually, these witnesses may be divided into three levels:

- Level One Witnesses: These are witnesses who are ready and willing to come

forward today, as a unified coalition, to disclose what they know about the subject. There are 44 such witnesses thus far identified.

- Level Two Witnesses: These are witnesses who have been identified but feel intimidated about coming forward and request the protection of congressional hearings and the protective effect of a congressional subpoena. They number 55.

- Level Three Witnesses: These are witnesses who are known to us but who are considered probably hostile or uncooperative witnesses. They would need to be subpoenaed and treated as potentially hostile witnesses. There are at least eight such witnesses in this category.

## THE WASHINGTON BRIEFINGS 7-11 April 1997

The purposes of the events of 7-11 April were as follows:

- To gather together bona-fide first-hand government UFO witnesses to further solidify the coalition of such witnesses who are willing to come forward with definitive, unambiguous information concerning the UFO/ET subject.

- To convene a closed, confidential briefing for members of Congress, congressional staff, White House staff, military leaders and other Washington leaders on the subject, and for these leaders to hear the direct

testimony of the US Government and military witnesses. This briefing was designed to present the best scientific evidence and witness testimony to establish the reality of the subject matter, and to ask specifically for open congressional hearings on the matter.

- To conduct a background educational briefing for interested members of the media.

- To provide private briefings to other military, intelligence and political leaders as needed.

All of the objectives listed above were met.

All members of Congress plus the President, Vice-President and key cabinet officials, as well as key military and intelligence leaders, were invited to the briefing. Further, they were offered the opportunity to receive private briefings at their convenience during the week.

On 9 April, a closed briefing was held for members of Congress and congressional staff, etc. Nearly 30 congressional offices were represented by either members of Congress or staff members. Also present were VIPs from the executive branch, foreign embassy staff, government scientists, representatives sent to the briefing by two state governors' offices, and many other dignitaries.

During the briefing, participants were introduced to a substantial Briefing Document which contains numerous scientific cases and over 250 pages of definitive and unambiguous US Government documents related to the subject. The government documents were selected from a larger collection of several thousand. Many were provided to CSETI by the CIA in 1994.

These participants also viewed a collection of excellent photographic, video and movie footage evidence spanning over 40 years and from every continent.

Eleven first-hand government and military witnesses were selected to testify before this group of government leaders. For over one and a half hours they provided definitive and unambiguous testimony regarding UFO/ET events. Their testimony ranged from a world-renowned astronomer who was present when an apparent extraterrestrial signal was received at the Harvard Observatory (SETI) facility; to an Eisenhower military top-secret witness who saw ET metal debris from a UFO

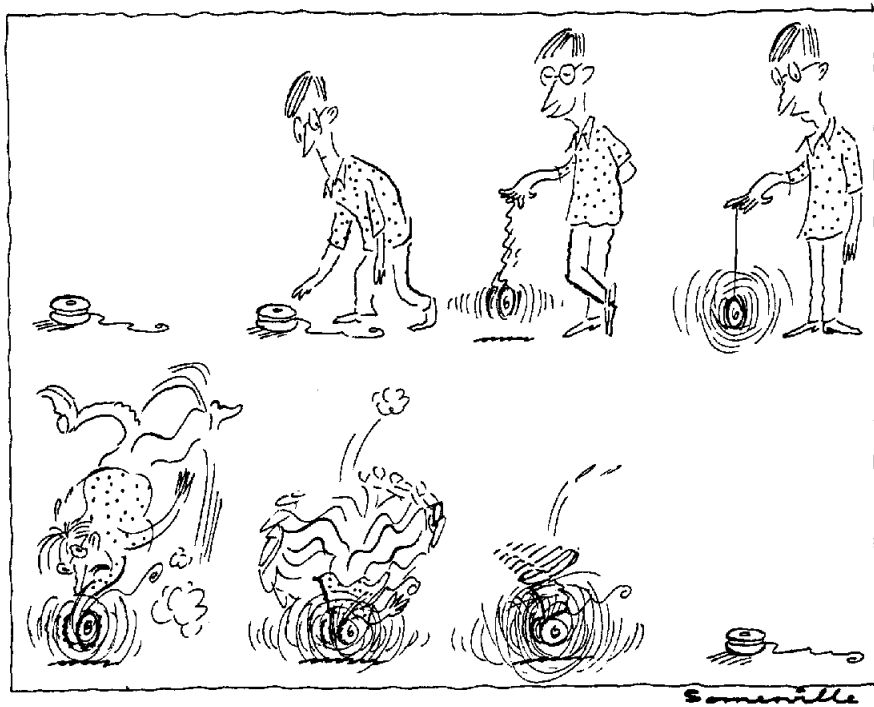

crash; to a NASA employee who saw a picture with a UFO, clearly in broad daylight, which was destined to be airbrushed out before release; to a Navy employee with a top-secret clearance who was present in 1981 during a major encounter off the eastern seaboard, which was tracked by satellite and radar and chased by military planes, with a resulting clear daytime photograph.

The richness of detail of this testimony and the down-to-Earth sincerity of these witnesses was very moving to the gathered officials.

At the end of the briefing, one of the congressional staffers came to the podium and, unsolicited by us, appealed to those congressional staffers and members of Congress gathered, to take definitive steps to let this information out to the public.

Numerous congressional offices represented at this historic briefing expressed a sincere desire to move this subject forward and to work with us in obtaining open congressional hearings as soon as possible. There was great enthusiasm for this, and one staffer from a congressional office has volunteered to coordinate these efforts in Washington with CSETI.

The combination of the extensive briefing materials, videotape evidence, first-hand witness testimony and the participation of so many congressional offices and other Washington leaders and dignitaries certainly constitutes the most historic civilian gathering in UFO/ET history.

In planning this event, we had hoped for positive RSVPs from five to 10 congressional offices. The participation of nearly 30 such offices, as well as representatives from the executive branch and two state governors, certainly exceeded our expectations.

Each congressional office and VIP was provided with:

- The CSETI Briefing Document and related case materials;
- The videotape summary of photographs, videos and movie footage of UFOs;
- A copy of the 1965 Edwards Air Force Base air traffic control tower

tape of multiple UFO encounters, with transcript.

Following the presentation, a number of congressional staffers remained to discuss this subject with the witnesses, CSETI staff and leaders.

On the morning of 10 April 1997, a briefing was held at the Pentagon for very senior military staff. The CSETI team present included five members: Dr Steven Greer, astronaut Edgar Mitchell, Shari Adamiak, CSETI's military advisor and an Eisenhower-era first-hand UFO/ET witness. This historic briefing lasted nearly one and a half hours and was enthusiastically received by senior Pentagon staff present.

During the afternoon, a follow-up with various congressional staffers, other Washington VIPs and the media took place.

At 7 pm there was a reception for an invitation-only media briefing. Uninvited media were not allowed into this meeting; for example, long-time debunker Phil Klass appeared without an invitation and was politely removed from the reception area. Similarly, had tabloid media appeared, they, too, would have been asked to leave. This meeting was a background educational briefing for major media only.

At 7:30 pm the media briefing began. Present were UPI, the *Boston Globe*, NBC, ABC the BBC and others. Seven first-hand witnesses provided statements to the media, and a general overview of the sub-

ject was provided by Dr Greer. Following the briefing, a question-and-answer period took place, and the media all had excellent and insightful questions.

It should be noted that the above meeting was a background press briefing, not a press conference. The purpose of the meeting was to provide scientific background materials, and to introduce the invited media to the concept of open congressional hearings on the subject. The CSETI media team felt that such a meeting would be an important step towards preparing the mainstream media for a future disclosure, and would encourage them to cover the subject in an informed and serious manner...

The time has come for the world to know that we are not alone in this vast universe. The era of excessive secrecy, which is so corrosive to a free and democratic society, must end. Working together, we can create a truly open and free society, which, through much deliberation and wise efforts, may someday take its place among other planetary civilizations.

15 April 1997

Steven M. Greer, M.D.

Director, Center for the Study of  
Extraterrestrial Intelligence (CSETI)  
PO Box 15401

Asheville, NC 28813, USA

Telephone: +1 (704) 274 5671

Fax: +1 (704) 274 6766

E-mail: Dr\_ET@compuserve.com

Website: www.cseti.org

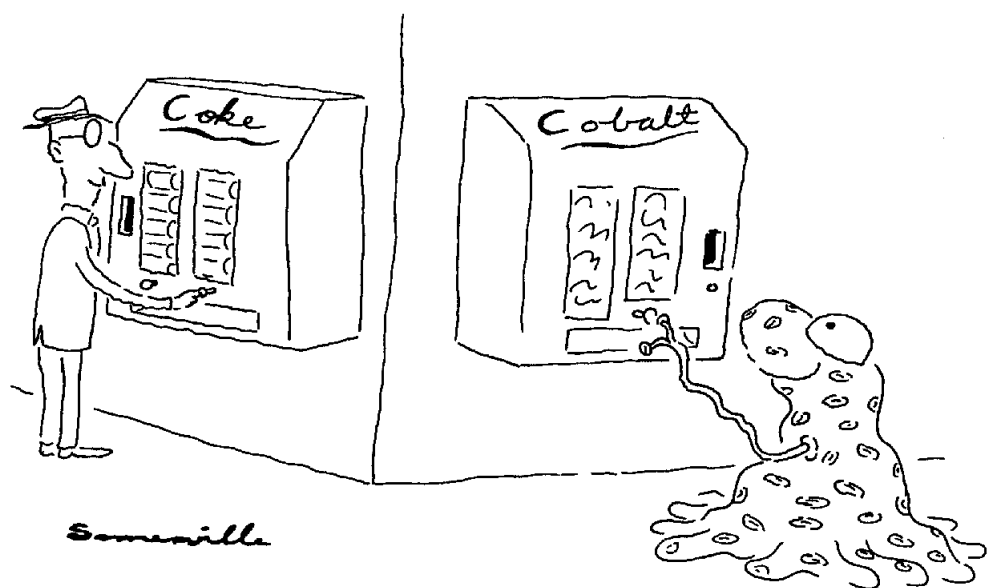





# — CHUPACABRAS —

## The Mysterious Bloodsuckers

*In 1995-96 a strange vampire-like creature went on the rampage in regions of Puerto Rico, Mexico and southern USA, killing animals and even attacking humans.*

*With links to UFOs and age-old fables, these 'chupacabras' incidents still defy explanation.*

by Linda Moulton Howe ©1996

LMH Productions  
PO Box 300  
Jamison, PA 18929-0300, USA  
Telephone: (215) 491 9840  
Fax: +1 (215) 491 9842  
E-mail: LMH333@AOL.com

There's a dangerous, mysterious beast lurking in the wilds of Puerto Rico," the San Juan *Star* newspaper announced on 19 November 1995. A similar creature that locals say punctures its victims and leaves bloodless holes made headlines in 1996 in Miami, Florida; Tucson, Arizona; San José, Costa Rica; and in Juárez and several other areas of Mexico. But it was Puerto Rico where the current cycle of vampire-like attacks was first reported.

On 11 March 1995, near a town called Orocovis in the centre of the island, Enrique Barreto Hernandez found eight of his sheep dead. Each sheep had three strange puncture holes in the chest, and the wounds were described as "bloodless". Over the spring and summer months, reports of similar attacks spread from the centre of the island to far-flung towns such as Guánica on the southwest coast, Naguabo on the east coast, and Canovanas between San Juan and El Junque rainforest. As word spread that blood was being sucked from sheep, goats and other farm animals by an unidentified creature, the Spanish words *chupar* ("to suck") and *cabras* ("goats") were put together in a catch-all word, *chupacabras*, as a name for the marauder.

By November, several hundred animals including goats, sheep, rabbits, chickens, dogs and guinea hens had been found with puncture holes which averaged about a quarter-inch wide and three-quarters of an inch deep. Veterinarian Dr Carlos Soto of Levittown, Puerto Rico, examined one rabbit that had an exceptionally deep wound. He reported that the "puncture wound was half a centimetre wide at the base of the jaw and extended about three to four inches into the base of the brain. There was no haemorrhaging either; no blood at all. I don't know what kind of natural predator could do that."

Eyewitness descriptions have varied in different parts of the island. On the west end, in the Sabana Grande and Lajas regions, there have been reports of a primate-like creature. For instance, on 21 December 1995 near Guánica on the southwestern coast, 44-year-old mechanic Osvaldo Claudio Rosado was washing his car at 3 am, but when he went to shut off the water faucet he was suddenly grabbed from behind. As Rosado tried to fight off the intruder, he was shocked to see a black-haired "gorilla", about five feet tall. The animal ran off and Rosado drove to the Tito Mattei hospital in Yauco to have doctors examine and treat cuts in his abdomen, possibly torn by fingernails or claws on the animal's hands.

I visited the University of Puerto Rico Primate Center which studies rhesus and patas monkeys now living inland. Those animals escaped from an island south of Lajas where a government research project was conducted in the 1960s. A Civil Defense investigator told me: "Back then, they didn't know those monkeys could swim. But they can, and now those monkeys live north of Guánica and Sabana Grande." However, rhesus and patas monkeys don't stand five feet tall and are basically vegetarians, not bloodsuckers.

At the other end of the island in towns such as Dorado, Aguas Buenas and Canovanas, residents have come face to face with a large-eyed creature that has red-coloured feathers or spikes from its head to the bottom of its spine. Some say the eyes glow red in the dark. Homicide detective Eliezer Rivera Diaz from Carolina, Puerto Rico, told television reporters that he watched the spikes on such a creature glow with light as it rose straight into the night sky.

The chupacabras' hands and feet are described as having only three toes and fingers but with two-inch-long nails. It is also said to have small, pointed ears and "thin, patchy or spotted hair" in shades of grey, brown and orange. "It smelled like a wet dog or like it had been in a sewer," said one Canovanas police officer who shot at a peculiar creature while it attacked his dog.

Some residents are convinced that the *chupacabras* is linked to the flying discs that are often seen in the skies above Puerto Rico. In June 1995, Mrs Enrique Gonzales and her six-year-old daughter were outside around 11.30 pm on a warm summer evening. Mr Gonzales heard both of them scream and immediately ran over to them, whereupon he saw a huge, round, glowing object. His wife and daughter told him they were watching the object when suddenly a red beam of light came out and touched the little girl on her upper right arm. Mr Gonzales reported that his daughter's skin reddened in a circle and "bubbled up" where she'd been hit with the beam.

Photographer Eddie Deese Conde, from *El Vocero* newspaper, eventually heard about the incident and travelled to the Gonzales' home. Conde told me later that by the time he got there the little girl's upper arm had several bumps, but the redness had gone.

Two months later in September, Mr Gonzales' wire chicken coop was violently torn apart and nine of the birds lay dead with bloodless holes in their necks, legs or backs. "It was the *chupacabras*," he said emphatically, "and I think it came from that UFO!"

Even though there was no direct or proven connection between the two incidents, the notorious *chupacabras* was beginning to be blamed for every animal death. Privately, many locals worried that the *chupacabras* might attack humans.

In the town of Canovanas, in the first week of August 1995, Miguel Agosta got up in the early morning to walk across the street from his home to the auto garage where he works as a



Drawing of a large, black creature with huge, round, red, reflective eyes, which computer technician Juan Murati saw as it sat in a tree near his home in Canovanas, Puerto Rico, at the end of September 1995. (Drawing by Juan Murati)

## The Carolina homicide detective said he watched in disbelief as the strange, glowing animal rose into the air.

mechanic. His wife, Madalyne, was home with their children and that day she was helping her mother who lived next door. Miguel's first job was to fix a truck he had left with its hood up the night before. He said that when he got into the driver's seat to start the engine, "There was a terrible noise, a loud thumping, and then I saw a creature land on the ground near me. It was about three to four feet high and it moved in a crawling way. But then it just stood next to the cyclone fence about eight feet away and jumped straight over into the tall grass. A few hours later, my wife and her mother saw the same creature on the sidewalk in front of our house."

Madalyne Agosta told me that she was helping her mother clean her house and was washing the front window when she saw two people walking backwards on the sidewalk, not more than five feet away, with their eyes wide open as if scared. Puzzled, she continued to watch and was shocked when a "creature I had never seen before" came walking slowly in front of her on the other side of the window.

"This creature was standing in front of me for at least a minute," Madalyne said. "And the thing that really impressed me were the eyes. I get scared every time I have to talk about this because it seems to me it looked like one of those extraterrestrials that you see in movies: long, slanted eyes that were dark grey. The whole eyes were like wet Jello. It was holding two hands up kind of limply and I could see three fingers that looked human except there were nails about two inches long. The feet looked human, too, but they had only three toes separated by big spaces in between. There was a lot of mud on the feet. Going down the back were red feathers or something about four inches long. When I started screaming, that's when my mother came."

Madalyne's mother told me, "At the beginning I thought it was a kangaroo because the nose and face was kind of long and pointed out a little. But when I saw the back, I could see some red feathers that were laid down. And I looked to see if it had a tail, but it had no tail. Then I thought it was not a kangaroo. Then it just started running across the street and hid itself in the grass."

The mud and water smell suggests that the creature hides out in sewer ducts, underground caverns and springs or somewhere that is wet. The situation is even more confusing when scattered reports that the *chupacabras* can fly are taken into consideration. The Carolina homicide detective said he watched in disbelief as the strange, glowing animal rose into the air. This high strangeness in the *chupacabras* reports has provoked some investigators to speculate that the creature might even be a new biological android created by whatever pilots the discs. More terrestrial explanations have been fruit bats or flying foxes which have big wing spans—but their bodies aren't four to five feet long.

**Finally, he managed to free himself and started running. Then he was startled to hear a loud noise, like a jet taking off. When Pulido turned and looked back, the creature had already mysteriously disappeared.**

And what was sitting on a tree branch near the home of computer technician Juan Murati at five o'clock in the afternoon at the end of September 1995? As he explained, "I was walking to my car when I had the feeling someone was looking at me. I take a glance and I see it, and I see the big red eyes, and I say, 'Chupacabras!' And I got worried, scared."

Pointing at a tree branch about 50 feet away, Juan said, "He was right there. He was sitting upright, not hanging down like a bat, but upright about two feet tall. And he was all black, a non-reflective black, like a bat, but non-reflective. The eyes were really round, the size of oranges. And the eye colour was red like a ketchup bottle or a Coca-Cola can. Very reflective, very glassy, the eyes. I kept walking without showing the animal I had fear. Then I hear this sound, 'plah, plah, plah, plah, plah', and he's flying away."

Juan Murati has his house surrounded by a tall chain-link fence with barbed wire on top and guarded by five pit bull dogs. One day, a month after he saw the black flying creature in the tree, he found his largest and strongest male pit bull with two puncture holes in its neck.

"I came here as I do every day to feed the dogs," Juan said, "and I saw the classical vampire marks on the big dog, the male. So I went to the police and from the police I went to Mayor Chemo Soto in Canovanas. He asked me what I thought it was—if I thought it was the demon, the devil, or from outer space. All I can say is I saw what I saw and that was it."

I showed a Philadelphia vertebrate biologist (who wishes to remain anonymous) several *chupacabras* drawings I have collected, including Juan Murati's sketch. The biologist emphasised that vampire bats don't sit upright in trees and don't make 3/4-inch-long punctures. Their front teeth are sharp and the bat makes several shallow cuts on its victim's skin and then licks off the blood. He doubted the credibility of the reports because "animals fall into categories which have long been studied and are recognisable. This is like a concoction that makes no sense, and therefore I doubt the accuracy of the eyewitnesses." When I showed him Juan Murati's drawing, he guessed the creature was an owl but admitted that owls are not solid black in colour.

#### CHUPACABRAS REPORTS BEYOND PUERTO RICO

On 11 May 1996, Molly Moore, reporting from Mexico City for the *Washington Post*, wrote: "First came the reports of goats, then lambs and roosters, massacred in the night and drained of their blood. The only evidence of their attackers: large fang marks on the animals' necks."

But Dr Mario Santiago Lara, a veterinarian from Zapotal, southeast of Mexico City, disagrees that the wounds are fang marks. "I have never seen anything like it, ever," he told *Houston*

*Chronicle* reporter Dudley Althaus in early May. "A coyote never kills the way these sheep were killed. The coyotes and jungle cats in the area devour their prey, rip it apart. The dead sheep had only puncture wounds."

The sheep that Dr Lara referred to belonged to Violeta Colorado, a 27-year-old mother with two small children. Colorado found nine of her sheep dead in a pasture next to her house. None of the sheep had been eaten, but their throats had been punctured, leaving bloodless holes. Several of the dead sheep were taken to Villahermosa, the Tabasco state capital about 30 miles away, for further examination. So far, no official reports have been released to the public.

Mexican eyewitnesses in close encounters with the *chupacabras* report hearing a screeching sound like a wild turkey or even a sound similar to a jet airliner taking off.

In the first week of May 1996, a man named José Angel Pulido from Tlajomulco, Jalisco state, reported to doctors and police that he was walking home through the small farming community at 11.30 pm when, ahead of him in the dimly-lit street, he saw a dark shape that he first thought was a dog lying asleep. When he got closer, the dark shape sprang for his head. Pulido said he felt pain in his right arm and tried to fight off the creature with his left arm.

He said the attacker had no hair and that when he was hitting it, it felt like "a plastic bag filled with soft jelly; no bones, no muscles". Pulido also said that the shape of the creature's head reminded him of an owl's—large and round. Finally, he managed to free himself and started running. Then he was startled to hear a loud noise, like a jet taking off. When Pulido turned and looked back, the creature had already mysteriously disappeared.

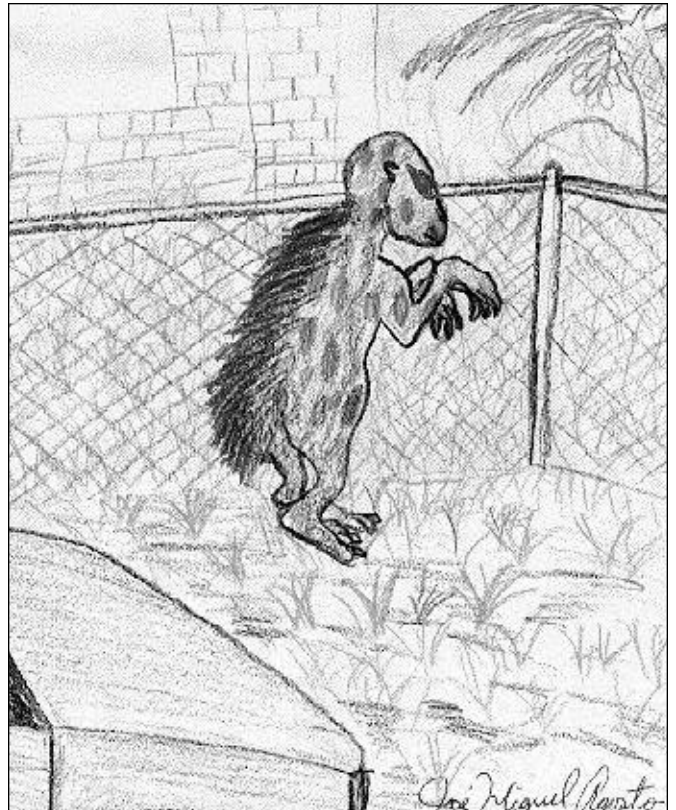

Drawing by José Miguel Agosta of the *chupacabras* creature he saw early one morning in the first week of August 1995. The unknown animal leapt from a truck that Agosta was repairing. It hit the ground about eight feet away and then leapt straight up over a chain-link fence and disappeared into tall grass.



The two puncture marks surrounded by a red inflammation, assumed to have been caused by the creature's mouth sucking on Mr José Angel Pulido's arm when it attacked him during the first week of May 1996 in Tlajomulco, Jalisco, Mexico.

(Photograph from Telemundo News videotape, with their permission)

Pulido's attacker put two puncture holes, each about one-quarter of an inch wide, in his right arm about two inches above his elbow crease. A third triangle-shaped puncture was evident in Pulido's right wrist where he thought his arm had been held while the creature sucked at the puncture holes. Videotape of the wound shows a reddish ring around the puncture holes that looks like a suction mark. Pulido said he felt nauseous for about three days afterward.

Some people wonder if the *chupacabras* is beamed up into an overhead UFO, especially since eyewitnesses in Juárez, Mexico, have reported seeing silver, saucer-shaped craft and strange, small beings since January 1996.

The NBC affiliate in El Paso, Texas, sent a camera crew to investigate. In one of their reports, broadcast 27 March 1996,



Juan Murati's pit bull dog suffered two puncture holes in its neck, just one month after Juan saw the black creature sitting in the tree near his house. This dog, one of five which patrol Murati's house as protection, survived the attack. "But," Juan asked, "how did anything get to my pit bull's neck like that without a horrible fight?" The dog had no other marks on its body and there were no signs of struggle inside the high barbed-wire fence that surrounds Juan Murati's home.

several Juárez children showed drawings of what they had seen. The drawings showed round objects, some with a row of coloured lights around the middle. One nine-year-old girl drew a picture of the creature that attacked her dog as she watched. Her drawing has several similarities to the creature drawn by Miguel and Madalyne Agosta in Canovanas, Puerto Rico.

A team of Mutual UFO Network (MUFON) investigators, led by Yolika Stone of El Paso, reported that "the area is very isolated and extremely poor. The people live in cardboard and tin shacks with no electricity or running water. It doesn't seem that they could have been influenced by something on TV because they don't have access to television.

"These children told us that there were two types of beings that appeared from UFOs on various occasions: one short and one slightly taller. The beings floated to the ground by a beam of light coming from the UFO that hovered one metre from the ground.

"The children told us of another incident with their school bus. A bright light hit the bus and the bus stalled. The light came from a UFO that hovered over the bus." The UFO was estimated to be 50 feet in diameter.

"The children also told us about their animals. The dogs were put into suspended animation. There were also animal mutilations of horses, dogs, sheep, goats and cows. Apparently they were bitten and the blood was drawn out."

Over the border in Tucson, Arizona, 28-year-old José O. Espinoza of North Palomas Avenue on the west side of the city, encountered a creature in the house in the early morning of 1 May 1996. "It had big red eyes, a pointy nose, pointy ears and a wrinkled face," Espinoza said. It "mumbled something" at him and "hopped away" into his seven-year-old son's bedroom, hopped up

onto the bed and then out of the open window. Espinoza said the animal smelled like a wet dog and left footprints and handprints all over his house. He called the police who came with an unfortunate attitude of ridicule, examined a handprint on the refrigerator door and told Espinoza it was his three-year-old son's handprint.

Whatever people are seeing in Puerto Rico, Mexico, Costa Rica and southern parts of the United States, there are correlations in the historical records of recurring cycles of events involving unknown creatures which attack animals.

## HISTORICAL REPORTS OF STRANGE ANIMAL KILLINGS

In the spring of 1975 in Moca, a town in the northwestern corner of Puerto Rico, "the Vampire of Moca" was on the rampage, killing livestock and scaring residents. On 15 March, the local newspaper, *El Vocero*, appealed to the government to investigate.

The first victims of "the Vampire" were

cattle. Then came a report from farmer Hector Vega Rosado who was shocked to find two of his goats dead with wounds under the thorax and above the haunches from something very sharp. The next day he found 10 more of his goats dead, seven wounded and another 10 missing altogether. He could see no blood around any of the one-inch- deep holes in the carcasses.

In 1925, the *Woodbury Daily Times* in New Jersey, USA, printed a detailed drawing by an alleged eyewitness of what was dubbed the "Jersey Devil". According to the newspaper report, a farmer found a strange beast that was consuming his chickens. He described it as being "as big as a grown Airedale with dark fur, having a kangaroo-fashioned hop; forequarters, higher than its rear, which were always crouched, and hind feet with four webbed toes. Its eyes are very yellow and its jaw is neither dog, wolf nor coyote. Its crushers in the lower jaws each have four prongs into which the upper teeth fit perfectly."

In December 1993, a park ranger named John Irwin was patrolling the Wharton State Forest in New Jersey. He reported that he "noticed a large, dark figure emerge from the woods. It stood like a human, over six foot tall, and it had black fur that looked wet and matted."

The official Forest Service report about the incident continued: "John sat in his car only a few feet away from the monster. His initial shock soon turned to fear when the creature turned its deer-like head and stared through the windshield. But instead of gazing into the bright yellow glow of a deer's eyes, John found himself the subject of a deep glare from two piercing red eyes."

In Europe and other countries, fables about mythical beasts of horrible form which attack people and animals have been passed down through the centuries. And back on the island of Puerto



José Angel Pulido from Tlajomulco in Jalisco state, Mexico, showing a Telemundo television reporter the puncture marks in his arm after the attack in early May 1996. (Photograph from Telemundo News videotape frame, with their permission)

Rico there is the tradition of the *plena*—songs which describe a "terrible animal" having an ox's head, a bull's horns and a serpentine tail. One of these songs implores, "Free us from all evil; protect us from this terrible animal".

What are these strange creatures that seem to 'recycle' themselves through the centuries? Are they some unknown, underground life-form that cohabits with us, the surface life of this planet? Do they come from UFOs, despatched like worker bees to gather tissue and fluids as part of some unknown agenda? Or do they slip into and out of an unimaginable place, another time, another space beyond this dimension? Whatever their origin, they have left behind hard physical evidence in the foreheads, necks, backs and stomachs of animals, both dead and still living. And thousands of people are afraid to go out after dark.

#### POSTSCRIPT

There have been no other reports of *chupacabras* attacks on humans since those May 1996 incidents described in this article, and puncture attacks on domestic animals have almost ended for unknown reasons. As quickly as the mystery began in March 1995, it seems to have come to an end, or at least a pause, in the summer of 1996.

#### About the Author:

Linda Moulton Howe is a graduate of Stanford University, USA, and has a Masters Degree in Communication. She has devoted her film/TV career to documentary and studio productions on science, medicine and the environment. Her documentaries, *A Strange Harvest* and *Strange Harvests 1993*, explored the worldwide animal mutilations which have been ongoing since the late 1960s. She has written several books, including *An Alien Harvest* and *Glimpses of Other Realities*, vols. I and II. Ms Howe's investigations have taken in such diverse subjects as the crop circles phenomenon, the evidence for UFOs and ETs, humanity's hidden history and, more recently, the *chupacabras* mystery.

For further information about the author's books and documentaries, contact LMH Productions (see details at the beginning of this article).



Drawing of the "Jersey Devil", based on an alleged eyewitness close encounter. It was published in a 1925 edition of the *Woodbury Daily Times*, New Jersey, USA.





# REVIEWS

## BOOKS

Reviewed by Ruth Parnell

### THE ROSWELL MESSAGE

by René Coudris

Publisher: Gateway Books, UK, 1997 (first publ. by F. A. Herbig Verlag, 1996)  
ISBN 0-85860-039-1 (192pp s/c)  
Price: AUD\$29.95; NZD\$35.00;  
STG£10.95; USD\$n/a

Available: **Australia**—Sydney Esoteric Bookshop, ph (02) 9212 2225 (available late August); **NZ**—Peaceful Living, ph (07) 571 8105 (late August); **UK**—Gateway Books, ph 01225 835127 (late July); **USA**—Gateway America, ph (707) 939 9212 (early August).

Controversy over the crash and recovery of an alleged alien spacecraft near Roswell, New Mexico, exactly 50 years ago, continues to capture the public imagination. But new information from a surprising source is about to trigger a whole new level of debate.

This information comes from a series of para-contact sessions held in August 1995, where two-way telepathic communication was established with, supposedly, the very aliens involved in the Roswell crash—or at least with their mental bodies which survived and reincarnated in new host bodies.

Austrian telepathic researcher/author René Coudris conducted these sessions with his wife, Mira, an experienced deep-trance medium. They knew few details of the Roswell incident before these sessions, but René has since become familiar with the available literature, which he presents in summarised form in the first part of his book, *The Roswell Message*.

The revelations these entities make are

indeed thought-provoking. They cover *their* perspective on details of the Roswell crash and government cover-up as well as data about their home planet, technology, reproduction techniques and their ancient links with humanity. Claiming to have travelled back in time from millions of years in the future, these beings have given a stern warning that we should *not* tamper with our genetics—lest we end up like them!

Certainly, René and Mira seem to be sincere in their approach, but whether this 'channelled' information is to be believed is up to the individual to ponder.

### MASTER R: LORD OF OUR CIVILISATION

by Michael Taylor

Publisher: The Rawley Trust, Christchurch, New Zealand, 1997  
ISBN 0-473-04337-8 (178pp s/c)  
Price: AUD\$30.00; NZD\$30.00;  
STG£12.00; USD\$20.00 (prices inc. p&h)  
Available: **New Zealand**—The Rawley Trust, PO Box 2831, Christchurch 8015, ph +64 (0)3 366 2943.

Certain extraordinary individuals have been responsible for great leaps in the progress of Western civilisation, but, according to 'secret' traditions, some of those individuals have been one and the same soul, expressed as different personalities through the centuries. One such 'master soul' is known as Master R., whose various incarnations have had a similar purpose: humanity's enlightenment. That such soul expressions might be possible requires some acceptance of reincarnation.

Master R., Lord of the 7th Ray, is well known to the Theosophists, Rosicrucians, Freemasons and in some New Age circles as

the Comte de St-Germain: the 'revolutionary' 18th century Hungarian Prince George Rakoczi who also lived as Sir Francis Bacon; as 14th/15th century Christian Rosencreutz, founder of Rosicrucianism; as 13th century scientist-monk Roger Bacon; and 4th century martyr St Alban, founder of Freemasonry.

Michael Taylor, in his book, *Master R: Lord of Our Civilisation*, highlights the esoteric links which do seem to suggest continuity of this master soul. He also adds to the list a few more Master R. 'lives', such as Columbus and Carl Jung, which may or not be accepted by the mystery schools.

While Taylor's coverage is necessarily somewhat brief, he has assembled fascinating material which will surely inspire readers to explore new realms of knowledge.

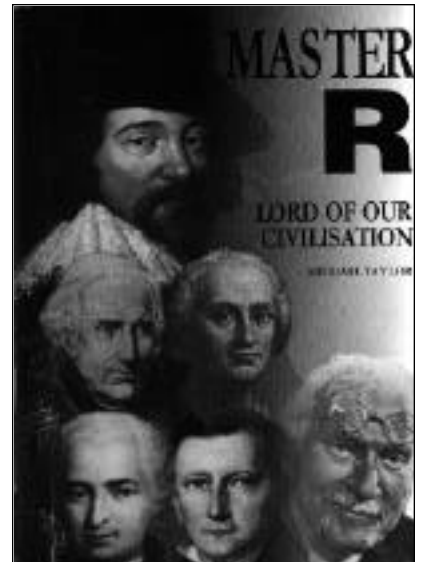

# REVIEWS



## BOOKS

### ENTER THE VORTEX AS ONE LIGHT: A Journey to Interdimensional Freedom by Sizzond Zadore (Jon Whistler)

Publisher: Light Pulsations, 1997; PO Box 102, Mowbray Heights, Tasmania 7250, Australia, ph 1-800 63 0290, fax +61 (0)3 6328 1539

ISBN 0-646-31591-9 (266pp s/c)

Price: AUD\$27.00; NZD\$36.00;

STG£16.50 (all prices include p&h)

Available: **Aust**—NEXUS Magazine, ph 07 5442 9280; **NZ**—NEXUS Office, ph 09 416 7320; **UK**—NEXUS Office, ph 01342 322854.

This book is the follow-up to *One Light*, Jon Whistler's story of the unearthing of an artefact through which the messages of Zadore were communicated—to awaken us all to the higher dimensional consciousness that is our true essence. This sequel has no storyline as such, but comprises those transmissions which could not be included in *One Light*, plus some comments from Jon Whistler and his companion Rose Medlin. (We recommend that you read *One Light* first; see review in NEXUS 3/04.)

The information imparted in the transmissions is *not* channelled; rather, it is described as a flow that comes from a true two-way connection with the "One Light". According to Sizzond Zadore, the first step in achieving this "surrender" to the "Vortex of Light" is for the individual to align the intellectual and emotional polarities that comprise the Ego or Soul. This assists one to break free from the illusion of the astral planes, particularly those lower realms inhabited by "Astral Lords"—entities who seek to main-

tain humanity's entrapment and manipulate human energy that they might free themselves from their own bondage.

This "Path of Freedom and Light" is not an easy one. Zadore reminds us that not even the so-called "new age" philosophies and disciplines are free from the tainted influence of negative astral vibrations, so it is up to each individual to be vigilant. However, attunement to the Vortex is about more than personal healing, for as each of us is an antenna of Light, self-healing ensures the healing of the Earth and galaxies beyond. This is an insightful, empowering collection.

### SOUNDING THE INNER LANDSCAPE: Music as Medicine by Kay Gardner

Publisher: Element Books, USA, UK, 1997; Jacaranda Wiley, Australia, 1997

ISBN 1-85230-973-3 (267pp s/c)

Price: AUD\$29.95; NZD\$29.95;

STG£9.99; USD\$16.95; CAN\$23.99

Available: **Aust**—Cameron Books, ph (047) 58 7676, fax (047) 58 9047; Sydney Esoteric Bookshop, ph (02) 9212 2225; **NZ**—Penguin Books, ph (09) 444 4965; **UK**—Element Books, ph 01747 851339; **USA**—Element Books, ph (508) 546 1040.

The use of music in ritual healing practices has been common among many cultures, both ancient and modern, but its healing role in the 'civilised' Western world has been downplayed in favour of aesthetic and entertainment values. In an attempt to redress this imbalance, musician/composer/spiritual therapist Kay Gardner has written this powerful book, *Sounding the Inner Landscape*.

She has devoted her career to exploring and explaining the mysteries and science of

music and developing ways of using sound as an integrative, therapeutic and transformative tool for promoting health on all levels—physical, emotional, mental and spiritual. The techniques she presents can be applied to self-healing or to aiding the health of others.

Gardner has written *Sounding the Inner Landscape* for composers and musicians who want to write and play healing music or who want to inject more 'spirit' into their work. She begins with an emphasis on the chakras, medicine wheels and tones, and the importance of clear, pure intent in the sound healing process. Drawing on Indian, Chinese, Tibetan and Greek legacies, she explains the functions of droning, toning, chanting and *mantra* in vibrational healing, and suggests a number of exercises for self-attunement.

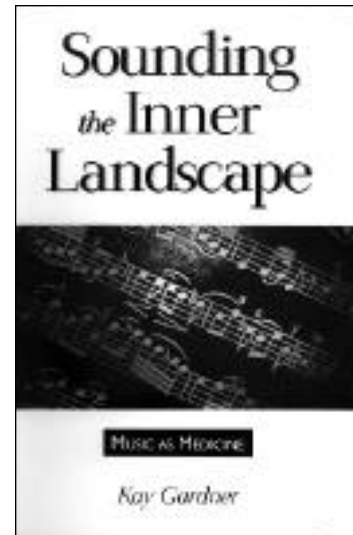





# REVIEWS

Gardner seeks to inspire a new understanding of the inherent sacredness of music and all its aspects, including harmonics, rhythm, melody, mood, metre and more. In teaching us to appreciate music's divine proportions, she reveals a whole new inner vibrational landscape that is accessible to the senses.

## THE GOD HYPOTHESIS: Extraterrestrial Life and Its Implications for Science and Religion by Joe Lewels, Ph.D.

Publisher: Wild Flower Press, USA, 1997  
ISBN 0-9226524-40-2 (295pp s/c)  
Price: AUD\$38.00; STG£n/a;  
USD\$18.95 + USD\$3.50 p&h  
Available: **Aust**—Cameron Books, ph  
(047) 58 7676; Sydney Esoteric B/shop,  
ph (02) 9212 2225; **UK**—Counterculture,  
ph 01823 698895; Wind Rush, ph 0608  
652012; **USA**—Wild Flower Press, ph  
(704) 894 8444, 1-800 366 0264.

A few years ago, author Joe Lewels, a journalism Ph.D. and media professor at the University of Texas, El Paso, made a significant career move when he applied his skills on a freelance basis in pursuit of an abiding curiosity: the UFO mystery. He had held a private fascination for the subject since his first aerial sighting over Alabama in 1968, so he resolved to come to grips with it.

Dr Lewels' research revealed a much wider context to the UFO phenomenon than he'd hitherto imagined. His book, *The God Hypothesis*, is a synthesis of the best of the available literature as well as his own findings. He arrived at his perspective as a result of his interviews with people claiming to have had extraterrestrial contact; his realisation that coming to terms with the evidence requires a shift in the conventional

scientific materialistic viewpoint; and his discovery that many ET contact reports have parallels with certain biblical accounts and historical events.

Lewels' reinterpretation of key events in the Old and New testaments certainly challenges the prevailing religious doctrines. His suggestion that Moses "may have been the most famous contactee in history" may shatter some cherished belief systems, as may one concerning Christ's Ascension on a UFO hidden within a cloud, and another, that ETs may have had a significant influence on the world's religions.

Lewels argues that, in the light of the evidence for holographic layers of existence occupied by hierarchies of entities, we may have to re-evaluate our hypotheses about the nature of God and creation.

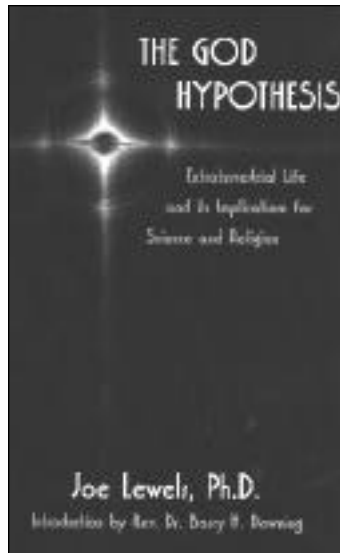

## COLLOIDAL SILVER: The Hidden Truths

by Keith F. Courtenay

Publisher: The House of Courtenay, Australia, 1997  
ISBN 0-646-30868-8 (264pp s/c)  
Price: AUD\$29.95 + AUD\$5.50 p&h; overseas orders add AUD\$10.00  
Available: **Australia**—The House of Courtenay, PO Box 125, Montville, Qld 4560, ph +61 (0)7 5442 9555; fax +61 (0)7 5442 9590.

It was only after years of trying to fight off a severe lung disease with antibiotics that Keith Courtenay realised his system was riddled with a chronic *Candida* yeast infection—caused by the antibiotics themselves.

In his search for alternatives, Keith stumbled across reference to colloidal silver as a universal germicide, able to kill up to 650 disease-causing micro-organisms including bacteria, viruses, fungi and yeasts.

He was surprised to find much early 20th-century literature about the efficacy of colloidal silver in medicine, and learnt that, with the introduction of antibiotics, its use was superseded and research was halted until the 1970s. Keith Courtenay was convinced enough by this data to start treating himself and experimenting until he found the most effective formula.

Inspired by his subsequent dramatic improvement in health, and that of others who have used colloidal silver to treat a variety of conditions, Keith decided to write *Colloidal Silver: The Hidden Truths*. Interwoven with his own story is material drawn from recent published articles plus selected medical papers, some going back nearly a century, covering colloidal silver's proven efficacy in medical practice.

# REVIEWS



## BOOKS

While colloidal silver is effective against a veritable A to Z of illnesses, Courtenay's selections by no means cover the full gamut, which may disappoint readers keen to treat specific complaints. In any case, his advice on what constitutes an effective colloidal silver formula is essential knowledge in making this universal germicide work for you.

### MIRACLES

by **Cassandra Eason**

Publisher: Piatkus Books, UK, 1997

ISBN 0-7499-1690-7 (178pp s/c)

Price: AUD\$22.95; NZD\$24.95;

STG£8.99; USD\$n/a; CAN\$n/a

Available: **Aust**—Cameron Books, ph (047) 58 7676; Sydney Esoteric B/shop, ph (02) 9212 2225; **NZ**—Dist. by David Bateman Ltd, ph (09) 415 7664; **UK**—Piatkus Books, ph 0171 631 0710; **USA/Canada**—Dist. by General Publishing, Don Mills, Ontario, fax (416) 445 5967.

In the whirl of our daily lives it's easy to dismiss the fact that miracles can and do happen, particularly as they tend to defy logic. This book reminds us that life is not always as random as it may seem.

In *Miracles*, well-known UK author/broadcaster Cassandra Eason says it is not uncommon for ordinary people all over the world to have life-changing, life-enhancing experiences that can only be described as 'miraculous'. A 'miracle', even when it can be explained in terms of natural phenomena, often involves synchronistic factors which suggest its occurrence was not a random event. Frequently, a belief in the power of love and prayer are factors, as is a



belief in the power of life, though belief in God or a divine cause is not a prerequisite condition.

Throughout these pages are dozens of stories from ordinary people whose lives have been touched by miracles. Their experiences affirm the power of miraculous intervention in healing the sick and dying against insurmountable odds; in establishing telepathic links beyond the physical world; and in rescuing people from almost certain death in wartime and in accidents.

Stories of weeping statues and dancing suns, and the transphysical abilities of Indian avatar Sai Baba, defy the sceptics but many who experience these miraculous signs and powers often report positive, inspirational changes in their lives.

Do 'miracles' happen more often to those who suspend their scepticism? This is an intriguing, optimistic book that could well change your view on life.

### ALTERNATIVE 4: UFOs, MIND & BODY CONTROL

by **Alder**

Publisher: Alpha Education, UK, 1996

ISBN 0-9529567-0-5 (458pp s/c)

Price: STG£17.50 inc. p&h in UK;

STG£21.50 inc. overseas p&h

Available: **UK**—Alpha Education Ltd, PO Box 2518, Rottingdean, East Sussex BN2 8EW, ph +44 1273 278640.

*Alternative 4* is an ambitious attempt to reveal the machinations behind the 'psycho-civilised society' that we are becoming—and which has been in the pipeline for 3,000 years. The book is written by a biochemist who has stepped way beyond the confines of her own scientific discipline.

The title suggests a development of the "Alternative 3" theme, and, indeed, it is all that and more, for it purports to reveal a devious conspiracy aimed at the enslavement of the human race and the "total dissolution of the spiritual memory".

Alder draws on the 'new science' field to try to explain the UFO phenomenon as well as potential dangers of HAARP and GWEN. These technologies, she argues, are the work of a secret cabal that has manipulated humanity and history through the millennia.

Alder claims to have deciphered symbols and codes from ufology which correspond to the occult symbology of some secret societies as well as to symbols of ancient cultures such as the Minoan—symbols which, in this case, suggest that in 1400 BC Crete was taken over by a patriarchal order who set into motion a diabolical plan that would seem to be coming to fruition in our times.

Alder distills a vast amount of research, but makes so many connections at once that it is easy to lose the thread of her argument.



# REVIEWS

## WHO KILLED THE DARLING BUDS OF MAY? 1) VACCINATION: What Vets Don't Tell You About Vaccines by Catherine O'Driscoll

Publisher: Abbeywood Publishing Ltd, Derbyshire, UK, 1997  
ISBN 0-9523048-1-3 (314pp s/c)  
Price: STG£16.47; other prices on appln  
Available: **Aust**—Viera Scheibner Publications, ph (047) 87 8203; **UK**—Abbeywood Publishing, PO Box 1, Longnor, Derbyshire SK17 0JD, ph +44 1298 84737, fax +44 1298 84739; **USA**—Abbeywood Publishing, PO Box 182, Danville, IN 46122; **Canada**—Out Pets Inc., ph (403) 553 4140.

Amidst the often heated discussion about the efficacy of vaccines, let us not forget the plight of animals in our care, for the same arguments on both sides of the debate are applicable regarding the vaccination of animals. Anyone who is seriously concerned for the welfare of their domestic pets or livestock should be aware of the facts before proceeding with vaccination—if at all.

Author Catherine O'Driscoll got involved in this issue when several of her cherished pet dogs suffered adverse reactions to vaccines. Two of the dogs ("the darling buds of May") died, and the others continue to have chronic autoimmune dysfunction.

As she discovered in her research, vaccine adverse reactions in animals are grossly underreported by veterinarians. The problem is further complicated by vets and vaccine producers insisting that animals receive an array of annual booster shots, often against diseases they are never likely to contract. While the drug companies do not recommend that unhealthy pets be vaccinated, vets go ahead anyway, oblivious to the mass of evidence that vaccines compromise the immune system on an ongoing basis.

O'Driscoll has gathered an array of heart-rending case studies, yet she has balanced the emotional concerns with cold, hard facts gleaned from discussions with vets and vaccine makers and drawn from both the veterinary and medical science literature which she quotes throughout her book. She also discusses homoeopathic alternatives which have few, if any, side effects and many reported successes.

For pets' sake, inform yourself!

## THE SHADOW OF ATLANTIS by Alexander Braghine

Publisher: Adventures Unlimited Press, USA, 1997 (first published in 1940)  
ISBN 0-932813-33-X (288pp s/c)  
Price: AUD\$25.00; NZD\$34.00 + p&h; STG£16.50; NFL\$19.90; USD\$16.95+p/h  
Available: **Australia**—NEXUS Magazine, ph (07) 5442 9280; **NZ/UK/Europe**—

NEXUS Offices; **USA**—Adventures Unlimited, PO Box 74, Kempton, IL 60946, ph (815) 253 6390, fax (815) 253 6300.

First published in 1940, Colonel Alexander Braghine's classic work, *The Shadow of Atlantis*, is still a fascinating and important treatise for its broad scope covering the anthropological, archaeological, cosmological, geological and historical evidence for the existence of a lost continent in the Atlantic Ocean.

Colonel Braghine, whose speciality was linguistics, eschewed the theosophical and anthroposophical approaches to Atlantean information-gathering. Despite the revelations that can be had using occult methods, he thought they fail to provide true descriptions of civilisations that existed and events which occurred many millennia ago. His approach was to draw on diverse scientific disciplines but without being so rigid as to reject the commonalities amongst the artefacts, languages and myths of many ancient and modern cultures around the globe.

When Braghine wrote this book, the related literature comprised more than 25,000 volumes, classical and modern, so he was not at a loss for research material. Braghine has proposed some convincing arguments that the continent of Atlantis did exist in the Atlantic Ocean and its territorial influence was so expansive as to take in South and Central America, Ireland, northern Africa and Egypt as well as Crete and Greece. His conclusion—that Atlantis was finally destroyed during a cataclysm caused by a close call with a comet some 11,000 years ago—is gaining greater acceptance amongst modern-day Atlantis researchers.

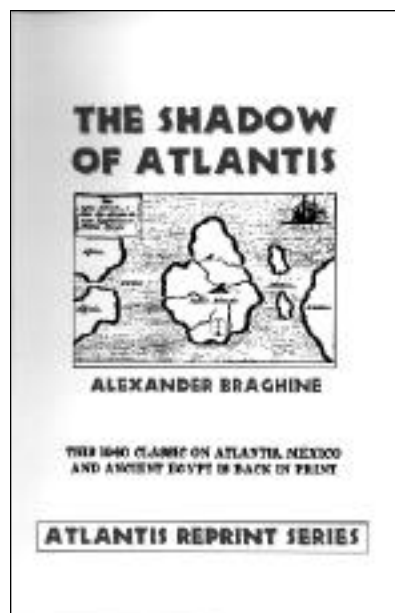

# REVIEWS



## BOOKS

### THE BENEFACITOR'S MONKEY

by Christopher Morten

Publisher: Christopher Morten, 1995

ISBN 0-646-25891-5 (350pp s/c)

Price: AUD\$15.00 inc. p&h in Aust;

AUD\$20.00 overseas p&h

Available: **Australia**—Morten Media, 9

Kawanna St, Mudjimba, Qld 4564,

ph/fax +61 (0)7 5448 7464.

Author Christopher Morten lived in Zimbabwe (then Rhodesia) off and on for 25 years (half his life), working in varied occupations including farmer, policeman and war correspondent. In late 1978, while serving as a volunteer in the Police Anti-terrorist Unit (PATU) in the northern war zone at the height of the Rhodesian civil war, he heard a medic warn confidentially of a highly contagious, lethal, unnamed sexually-transmitted disease that was being carried by black insurgents entering the Zambezi Valley. Because of an ethical conflict he was unable to report on this at the time.

However, it was not until several years later that the significance of this "New Death" struck him: he realised he had seen the first days of the terrifying scourge of AIDS. But how could so much already have been known about this deadly agent back in '78, when it didn't even have a name? Was a much more sinister plot behind it?

Morten has woven his hypothesis about the origin and purpose of this disease into a gripping yarn, *The Benefactor's Monkey*. His scenario involves a genetics genius being recruited by his rich, powerful uncle ("the benefactor") who is connected to an

elite group intent on reducing the world's population by 250 million a year. The geneticist is commissioned to produce a biological agent that would quickly wipe out the unwanted millions. He succeeds, but also creates an antidote as "insurance".

Though written as a fiction thriller, Morten's story contains many elements of truth in view of the mounting research pointing to AIDS being man-made.

### ANCIENT TONGA & THE LOST CITY OF MU'A

by David Hatcher Childress

Publisher: Adventures Unlimited Press, Illinois, USA, 1996

ISBN 0-932813-36-4 (216pp s/c)

Price: AUD\$25.00; NZD\$32.00 + p&h;

STG£16.00; NFL£31.90; USD\$15.95+p/h

Available: **Aust**—NEXUS Magazine, ph

(07) 5442 9280; **NZ**—NEXUS Office, ph

(09) 416 7320; **UK**—NEXUS Office, ph

01342 322854; **Europe**—NEXUS Office,

ph +31 (0)321 380558; **USA**—AUP, ph

(815) 253 6390.

From the intrepid David Hatcher Childress comes this absorbing investigation into the archaeological and anthropological history of the great Polynesian empire that once existed with Tonga at its centre. He has encapsulated an impressive array of evidence and research that suggests the region evolved in stages, being subject to migration waves and periodic influences from India, Egypt, Phoenicia, Libya, East Africa, South America and China. The fact that islanders of different racial heritages, separated by huge distances, use similar root words in their languages only deepens the mystery.

Scattered through the islands of Tonga, Samoa, Fiji and Rarotonga are the ruins of megalithic structures—pyramids, platforms, tombs, as well as roads, wharves, forts and moats—that point to a much earlier civilisation, one which had well-developed astronomical and technical skills in common with other now-lost megalithic cultures. This begs the question of whether a vast land (Mu or Lemuria), occupied by an advanced culture, did once exist in the Pacific Ocean—until it was ravaged by Earth changes many millennia ago.

Childress has reprinted some choice archival photos, illustrations, maps and symbols and contributed many of his own on-site colour photos of such wonders as a massive trilithon stone arch in the lost city of Mu'a on Tonga, and the recently discovered stone wall in New Zealand which is similar to ancient walls found in much of Polynesia.

Unlike many books by Childress, this is not a travelogue as such, but its engrossing narrative will nevertheless transport the reader for a glimpse into lost worlds.

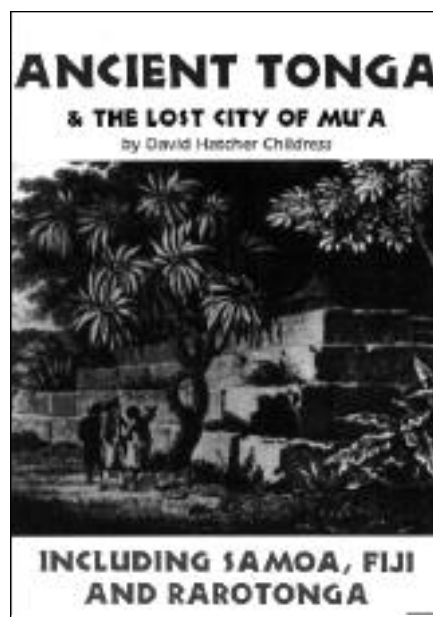



# REVIEWS

## **BEYOND ROSWELL: The Alien Autopsy Film, Area 51 & the US Government Coverup of UFOs**

by Michael Hesemann & Philip Mantle

Publisher: Marlowe & Company, New York, USA, 1997

ISBN 1-56924-781-1 (303pp h/c)

Price: AUD\$45.00; STG£15.99;

USD\$22.95

Available: **Aust**—Cameron Books, ph (047) 58 7676; **UK**—Michael O'Mara Books, ph 0171 720 8643; **USA**—Publ. Group West, ph 1-800 788 3123.

Fifty years after the infamous Roswell incident, isn't it high time the US government ended the cover-up on the truth about UFOs/ETs? This sentiment is echoed in *Beyond Roswell's* foreword, written by Jesse Marcel, MD, who, in 1947 at age 11, was shown debris from a UFO crash retrieval site by his father, Major Jesse Marcel, whose name is now legendary in ufology.

Michael Hesemann (editor of the German UFO publication, *Magazin 2000*) and Philip Mantle (investigations director of BUFORA in the UK) have teamed up to produce as definitive an examination as possible of the events surrounding the Roswell UFO/alien crash retrieval scenario. They have drawn on the available archival material concerning the circumstances and the personalities involved with Roswell, as well as the 'body of knowledge' painstakingly built up since the late 1970s by researchers like Stanton Friedman. Hesemann and Mantle have added to the storehouse their own interviews with still-living eyewitnesses and have included archival and recent photos of key

players so as to put faces to names.

The authors expand upon recent revelations over the Santilli autopsy film as well as the theory that the autopsied alien was retrieved from an earlier 1947 crash site at Socorro, NM (see Hesemann's article in NEXUS 3/06).

Included are analyses by Hesemann, and Native American Robert Morning Sky, of hieroglyphs, retrieved from the crash site, which have remarkable similarities with a number of ancient Earth scripts.

One thing is certain: the Roswell phenomenon is not going to go away!

## **BETRAYAL OF THE SPIRIT: My Life Behind the Headlines of the Hare Krishna Movement**

by Nori J. Muster

Publisher: University of Illinois Press, USA, 1997

ISBN 0-252-02263-7 (231pp h/c)

Price: USD\$24.95 + p&h

Available: **USA**—University of Illinois Press, ph (410) 516 6927, 1-800 545 4703, (217) 333 0950 (orders).

Betrayal of the spirit is a rare glimpse into the workings of the Hare Krishna movement in the US by a former insider. Author Nori Muster joined the International Society for Krishna Consciousness (ISKCON) in 1977 and left in 1988, disillusioned with the way that the mechanisms of the institution interfered with her pursuit of spiritual truth.

Nori Muster joined the group not long after the death of its founder and master, Swami Prabhupada—which ushered in an era of considerable disarray for ISKCON. In her position as public relations secretary and an editor of *ISKCON World Review* Muster was especially privy to the group's workings and many times had to present cover stories to soften the impact of the many scandals that rocked the movement—scandals involving membership schisms, fund-raising anomalies, child abuse, drugs, weapons stockpiling and even murder.

Her narrative serves on two levels: as behind-the-scenes historical reportage and as a very personal account of her journey into Krishna consciousness and her search to find meaning within the confines of religious institutionalism. Despite her frustration with the inner workings and the rampant religious hypocrisy and sexism that forced her to leave her job and the group in 1988, Nori remains true to her spiritual path and even sympathetic about ISKCON and its shortcomings.

Nori Muster's balanced critique gives many helpful insights for those seeking a better understanding of the structure and nature of religious cult groups at the fringe of society.

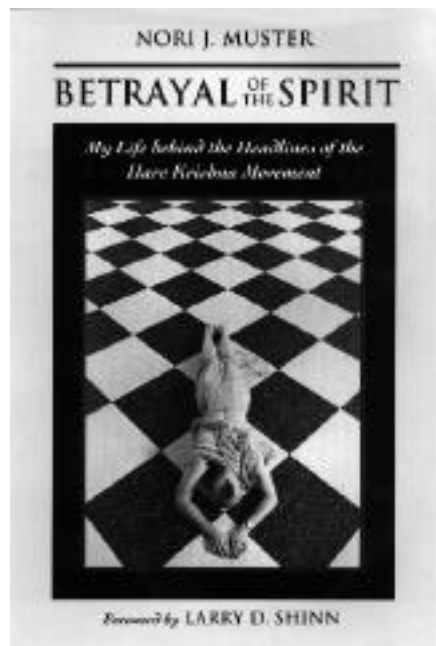

# REVIEWS



## CHILDREN OF A TOXIC HARVEST by Eve Hillary

Publisher: Lothian Books, Victoria, Australia, 1997

ISBN 0-85091-850-2 (190pp s/c)

Price: AUD\$19.95; NZD\$29.95;

STG£11.99; USD\$/n/a

Available: **Aust**—Cameron Books, ph (047) 58 7676; Sydney Esoteric B/shop, ph (02) 9212 2225; **NZ**—Forrester Books, ph (09) 415 2080; **UK**—Gazelle Book Services, ph 01524 68765; **USA**—Seven Hills Book Distributors, ph (513) 381 3881.

A new breed of 'heroes' is emerging in the latter 20th century: individuals who have endured enormous suffering due to environmental illness, yet have managed to summon the strength to improve their own lives and warn the rest of us that we are all at risk.

One such champion is Eve Hillary, a registered nurse, who experienced debilitating health symptoms for over 10 years before she found a doctor who diagnosed her condition as chronic fatigue syndrome brought on by multiple chemical sensitivity. He started her (and her son) on a path of recovery with chemical-detoxifying chelation therapy and immune system-boosting treatments.

Eve's nightmare began in 1982 when, working with her now ex-husband on their isolated NSW property, she was exposed to sheep-dip chemicals and a multitude of toxic agricultural pesticides and herbicides. She was three months pregnant when first exposed, and her son went on to develop a host of health problems including acute lead poisoning and behavioural difficulties.

Eve had no idea then that their farm chemicals were the cause of her immediate and quickly worsening symptoms, such as severe migraine, nausea and dizziness. This energetic person soon had trouble even lifting a finger. As she eventually discovered, her immune system had been so compromised that she developed acute sensitivity to a

plethora of household chemicals, environmental pollutants and food preservatives—forcing her to adopt a total change in lifestyle. Her real-life story, *Children of a Toxic Harvest*, is testimony to her triumph over adversity as well as a call to remedial environmental action.

## LECTURE TAPE

Reviewed by Richard Giles

## THE SECRETS OF THE VATICAN Lecture by Simon Treselyan

Producer: Seventh Wave Seminar Promotions, Qld, Australia, 1996

Price: AUD\$25.00 + \$3.00 p&h in Aust; STG£12.50 + £1.50 p&h in UK (3hrs, double cassette)

Available: **Australia**—Seventh Wave Seminar Promotions, PO Box 171, Woodford, Qld 4514, ph +61 (0)7 5496 4653; **UK**—Simon Treselyan Seminars, ph +44 01332 672104.

Simon Treselyan, guest speaker at the 1997 NEXUS Conference, presents a fascinating, revealing and even witty coverage of the history of the major religions, with a special focus on the Papacy, Templars and Masons. He looks at CIA and Mafia links with organised religion, the coming collapse of the system and the dawning of a new age of honesty. In this lecture given in Sydney in November 1996, Treselyan recounts amazing stories of corruption, manipulation and murder behind the scenes of churches, banks and governments. His past experience with the intelligence community means he is well qualified to speak on these subjects.

## VIDEO

Reviewed by Duncan Roads

## 1996 AUSTRALIAN INTERNATIONAL UFO SYMPOSIUM, Vols. 1-14

Producer: QUFON, Australia, 1996

Price: AUD\$29.95 each + p&h (PAL/VHS)

Available: **Australia**—MUFON (Qld), PO Box 2183, Mansfield MC, Qld 4122, ph/fax +61 (0)7 3849 6450.

Vol.1: Walt Andrus (Director, MUFON)

Vol.2: Keith Basterfield + Kelly Cahill

Vol.3: Peter Davenport + Alec Newald

Vol.4: Ademar Gavaerd (Brazil)

Vol.5: Soledad Wilson + Moira McGhee

Vol.6: Dr Joe Lewels + David Summers

Vol.7: John Carpenter (USA)

Vol.8: Jaime Maussan (Mexican UFOs)

Vol.9: Bill Chalker + Warren Aston

Vol.10: Stanton Friedman (USA)

Vol.11: George Wingfield (UK)

Vol.12: Pat Bailey + Glennys Mackay

Vol.13: Prof. John Mack on abductions

Vol.14: Whitley Strieber (USA)

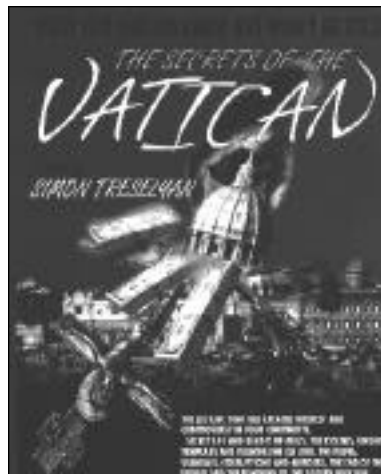



# REVIEWS

## AUDIO

Reviewed by Richard Giles

### SOUND THERAPY SELECTIONS

Featured here are several sound therapy CDs which employ vibrational frequencies to heal body, mind and spirit.

### ACOUSTIC RESEARCH SERIES:

(1) **Brainwave Journey**; (2) **Brainwave Suite**; (3) **Delta Sync Sleep System**  
by Dr Jeffrey Thompson

Producer: Relaxation Company, '95-'96  
Available: **Australia**—New World Productions, Red Hill, Qld, ph (07) 3367 0788; **USA**—The Relaxation Co., Roslyn, NY, ph 1-800 788 6670.

**1. Brainwave Journey:** This 4-CD set is designed to decrystallise mental patterns and belief systems that prevent one from achieving full potential. With imagery instructor Owen Morrison, Dr Thompson uses embedded pulse sounds, comprising alpha, delta and theta waves, in a soundtrack with spoken words to guide the listener to a relaxed, altered state of consciousness.

**2. Brainwave Suite:** These CDs stimulate the brain to produce natural wave patterns to match one's desired state of mind. Naturally derived 3D sounds are combined with beta, alpha, theta and delta frequencies to entrain the brain with 'maps' of sound for fostering creativity, relaxation, insight, stress release, rejuvenation and other preferred states.

**3. Delta Sync Sleep System:** A 2-CD set designed to coax the body's own brainwave frequencies into a deep, rejuvenating sleep state. As most sleep problems result from prolonged stress, this sound approach promotes the relaxation necessary for entering deep sleep. An accompanying 12-page booklet explains how it all works.

### BIO-ENERGETIC PSYCHOTROPIC MUSIC

by Boris Mourashkin

Producer: The Relaxation Co., 1995  
Available: **Australia**—New World Prodn, ph (07) 3367 0788; **USA**—The Relaxation Co., ph 1-800 788 6670.

The music therapy developed by Siberian healer/poet/composer Boris Mourashkin differs from other sound therapies in that it stimulates the widest range of frequencies within the human audio and kinesthetic range of perception. It is a healing music that has been shown to enhance immune system responsiveness, and has been used successfully to treat dental patients, the chronically ill as well as handicapped children. The efficacy of Mourashkin's techniques is now being praised by medical health practitioners in the US where Mourashkin now resides.

### HARMONIC RESONANCE

by Jim Oliver

Producer: Jim Oliver for The Relaxation Company, NY, USA, 1995

Available: **Australia**—New World Productions; **USA**—The Relaxation Co., Roslyn, NY, ph 1-800 788 6670.

Jim Oliver has been playing piano since the age of five, and in the course of his musical development he discovered that different sounds resonate within different parts of the body. By applying these principles, he developed an approach for his workshops and recordings using sound to stimulate body cells. He uses the base note frequencies as carrier waves for higher frequencies. By interweaving sounds and emotions, his harmonic resonance compositions are designed to carry the listener beyond the physical to a deeper-level soul healing.

### HEALING KEY

by SPIN.FX

Producer: Luis Miguel Trapaga, ND, for SPIN.FX, Australia, 1996

Available: **Australia**—SPIN.FX, PO Box 230, Neutral Bay, NSW 2089, ph +61 (0)2 9909 1654.

Luis Trapaga, a naturopath and sound engineer/composer, uses sound frequency as a therapeutic tool. In creating *Healing Key* he recorded male and female voices chanting "Om", then filtered out the frequencies that diverged from the targeted seven main notes. The tracks, each 7.5 minutes long, comprise the tuned frequencies of the seven main chakras, starting with the base chakra, "C", at 261.63 Hz. The effect of the tones is extraordinary.

This is a valuable therapeutic technique, useful in massage, meditation, making vibrational remedies, etc. The CD comes with a chart that lists the colour, spinal nerve, aromatic oil, Bach remedy and gemstone corresponding to each chakra.

### NAKED DIDGE

by Dr Didge

Producer: Tarshito for Dr Didge, NSW, Australia, 1997

Available: **Australia**—Dr Didge, "Rainbow Hill", Fox Rd, Rosebank, NSW 2480, ph +61 (0)66 88 2290.

"Dr Didge", a medical doctor practising in northern New South Wales, has been experimenting with toning, tuning forks and didgeridoo for many years. He utilises the laws of sympathetic vibrational resonance to produce healing music. On this CD he employs the ancient sound of the didge to stimulate the seven main chakras and elevate body and mind. The first nine tracks focus on chakra stimulation, and the next five encourage freedom of movement, voice and breath. Excellent spirit/body workout.





Continued from page 16

mote, during school time, confluences of parent and child that will strengthen family bonds. That was my real purpose in sending the girl and her mother down the Jersey coast to meet the police chief.

I have many ideas to make a family curriculum, and my guess is that a lot of you will have many ideas, too, once you begin to think about it. Our greatest problem in getting the kind of grassroots thinking going that could reform schooling is that we have large, vested interests profiting from schooling just exactly as it is, despite rhetoric to the contrary.

We have to demand that new voices and new ideas get a hearing—my ideas and yours. We've all had a bellyful of authorised voices on television and in the press. A decade-long, free-for-all debate is called for now—not any more 'expert' opinions. Experts in education have never been right; their 'solutions' are expensive, self-serving, and always involve further centralisation. Enough!

Time for a return to democracy, individuality and family.

I've said my piece. Thank you.

**Editor's Note:** *We asked Mr Gatto if he'd write a few words on what had transpired since he delivered the above speech. He wrote the following in reply. We should note that, when he'd decided to stop teaching in the school system, he had no idea exactly how he was going to generate an income.* — J. W., *HOPE Magazine*

Dear Jon,

A year and a half after I gave that speech, I quit teaching (on the Op-Ed page of the *Wall Street Journal*, July 25, 1991). A week later, I was asked to speak to the engineers at NASA-Goddard Space Center, and a week after that I was at the White House. Then in rapid order I was invited to open the full season at the Nashville Center for the Arts, be the Keynote speaker for the Colorado Librarians Convention, and spend eight private hours with the comptrollers of the 32 operating divisions of United Technologies Corp. in Hartford, CT. From there to The Farm commune in central Tennessee, an Indian reservation in New Mexico, and a Christian home-school convention in Atlanta.

All in all, since I quit teaching five years ago, I've given 522 talks and workshops in 49 states (missed Oklahoma) and six for-

eign countries. I don't advertise, but I go anywhere I'm invited as long as my hosts don't tell me what I have to say.

Being in an airplane seat about one day in every two has added 85 pounds, so I expect to translate to the spirit world momentarily if I don't come up with a strategy, but in the meantime I've met an amazing cross-section of fine and courageous ordinary people from every point on the political/social spectrum—enough to convince me an American renaissance is latent in the common folk of this country if we can figure out a way to restore the democratic promise.

I think we will. I have faith, as well as hope, that we can do it.

— John Taylor Gatto

**About the Author:**

John Taylor Gatto, a New York City public school teacher for 30 years, was named NYC Teacher of the Year in 1989, 1990 and 1991, and NY state Teacher of the Year in 1990 and 1991. He is the author of *Dumbing Us Down*, *The Exhausted School*, and *The Empty Child: A Schoolteacher's Intuition about the Problem of Modern Schooling* (due out in early 1998 from Simon & Schuster).

Continued from page 29

agenda all along was to curb women's fertility through the use of synthetic hormones in the hope of putting the reins on the overpopulation problem. Along the way, it also spawned a multi-billion-dollar industry for the pharmaceutical companies and medical researchers.

One prominent clinical researcher has compared the Pill to the Vietnam War: "We got into it with the best intentions and now we don't know how the hell to get out."<sup>33</sup>

The change that is needed to stop the exploitation of women's health for profit will require women as well as conscientious health professionals to make new, informed, safe choices. The health and well-being of millions of women worldwide and the health of future generations must no longer be sacrificed for any cause.

**Note:** Part 2 will cover the Pill's links with heart disease, strokes, blood clots, nutritional deficiencies, birth defects and infertility—as well as the Pill's effect on women's psycho-spiritual health.

To be continued next issue...

#### Endnotes

1. Archer, John, *Bad Medicine*, Simon & Schuster, Australia, 1995, p. 210.
2. *Australian Prescription Products Guide (APPG)*, Minulet monograph, 1995, 24th ed., p. 1540.
3. Seaman, Barbara, *The Doctors' Case Against the Pill*, Hunter House, USA, 1995, p. 7.
4. *ibid.*, p. 225.
5. *The Australian Journal of Pharmacy*, vol. 76, February 1995, p. 112.
6. Grant, Ellen, M.D., *Sexual Chemistry*, Reed Consumer Books Ltd, UK, 1994, p. 23.
7. *ibid.*, p. 38.
8. Wilks, John, *A Consumer's Guide to the Pill and Other Drugs*, Freedom Publishing Company Pty Ltd, Australia, 1996, p. 16.
9. Rahwan, Prof., *Contraceptives, Interceptives and Abortifacients*, College of Pharmacy, Ohio State University, Ohio, USA, 1995, pp. 7.
10. Wilks, op. cit., p. 17.
11. Rahwan, op. cit., pp. 7-8.
12. Seaman, op. cit., 223.
13. *ibid.*
14. *ibid.*
15. op. cit., p. 225.
16. *ibid.*
17. op. cit., p. 226.
18. Chilvers, C. et al., "Oral contraceptives use and breast cancer risk in young women", *The Lancet*, 6 May 1989, pp. 973-982.
19. Miller, D. R., Rosenberg, L. et al., "Breast cancer before age 45 and oral contraceptive use: new findings", *American Journal of Epidemiology* (1989) 129(2):269-80, Ma.
20. Romieu, I. et al., "Oral contraceptives and breast cancer: Review and meta-analysis", *Cancer* (1990) 66(11):2253-63.
21. Wilks, op.cit., p. 58.
22. op. cit., p. 59.
23. *ibid.*
24. op. cit., p. 84.
25. Grant, op. cit., p. 190.
26. Wilks, op. cit., p. 39.
27. *ibid.*
28. Grant, op. cit., p. 194.
29. op. cit., p. 37.
30. Beral, V., Ramchara, S., Faris, R., "Malignant melanoma and oral contraceptive use among women in California", published in *The Walnut Creek Contraceptive Drug Study*, NIH, vol. III, 1986, pp. 247-52.
31. Beral V., Evans, S., Shaw, H., Milton, G., "Oral contraceptive use and malignant melanoma in Australia", *Br. J. Cancer* (1984) 50:681-85.
32. Naish, Francesca, *Natural Fertility*, Sally Milner Publications, NSW, Australia, 1991.
33. Seaman, op.cit., p. 14.

#### About the Author:

Sherrill Sellman runs a private psychotherapy practice in Melbourne. She lectures extensively on women's hormonal health and is also the author of the best-selling book, *Hormone Heresy: What Women Must Know About Their Hormones*. She is a contributing writer to publications in Australia, NZ, Canada and the US.

This June 1997, Sherrill is giving a series of lectures in southeast Queensland and Tasmania. For more information, contact Light Unlimited (see details on first page).

Continued from page 35

- Kevles, Daniel J. and Hood, Leroy (eds), *The Code of Codes: Scientific and Social Issues in the Human Genome Project*, Harvard University Press, UK, USA, 1992.
- Kimbrell, Andrew, *The Engineering and Marketing of Life*, HarperSanFrancisco, USA, 1993.
- Lyon, Jeff and Gorner, Peter, *Altered Fates: Gene Therapy and the Retooling of Human Life*, W. W. Norton & Company, Inc., New York, 1995.
- Packard, Vance, *The People Shapers: Is Science Shaping Man?*, Future Publications, 1978.
- Proctor, Robert N., "Nazi Biomedical Policies" in *When Medicine Went Mad: Bioethics and the Holocaust* (Arthur Caplan, ed.), Humana Press, New Jersey, USA, 1992.
- Reiss, Michael J. and Straughan, Roger, *Improving Nature? The Science and Ethics of Genetic Engineering*, Cambridge University Press, UK, 1996.
- Science and Engineering Council, *Gene Technology*, Office of the Chief Scientist, Department of the Prime Minister and Cabinet, Australia, 1993.
- Shiva, Vandana and Moser, Ingunn, *Biopolitics: A Feminist and Ecological Reader on Biotechnology*, Zed Books, London, 1995.
- Sitchin, Zecharia, *Genesis Revisited*, Avon Books, New York, 1990.
- Walmsley, Jane and Margolis, Jonathan, *Hot House People: Can We Create Super Human Beings?*, Pan Books, London, 1987.
- Weir, Robert F., Lawrence, Susan C., Fales, Evan, *Genes and Human Self-Knowledge: Historical and Philosophical Reflections on Modern Genetics*, University of Iowa Press, Iowa City, USA, 1994.

References: Journal Articles

- *RAFI Communiqué*, May/June 1995, March/April 1996, January/February 1997, March/April 1997.

- "Gene superclub signs up top players", *New Scientist*, 19 November 1994, p. 4; "Squabbling all the way to the genebank", *New Scientist*, 26 November 1994, pp. 14-15.
- "Mapping the human body: Ethical and legal implications of the Human Genome Project", *Alternative Law Journal*, vol. 8, no. 5, October 1993, pp. 240-241.
- "The political economy of genes", *Journal of Australian Political Economy*, no. 36, December 1995, pp. 104-113.
- "Current research project on the legal and ethical aspects of genetic research in Australia", *Journal of Law and Medicine*, vol. 3, no. 1, August 1995, pp. 30-35.
- "Rumour, bloody rumour: Vampire Project—the Human Genome Diversity Project", *Time Australia*, vol. 9, no. 6, 7 February 1994, p. 49.
- "Fast track for false promises: genetic engineering", *Habitat Australia*, vol. 22, no. 1, February 1994, pp. 38-43.
- "New dilemmas for law and medicine", *Reform the Law: Essays on the Renewal of the Australian Legal System*, 1983, pp. 217-242.
- "Genetic engineering: miracle or menace?" *Chain Reaction*, no. 62, October 1990, pp. 24-29.
- "Human Genome Diversity Project", *Search*, vol. 25, no. 3, April 1994, pp. 85-90.
- "Human DNA: cracking the code—implications of the Human Genome Project", *21C: Previews of a Changing World*, Summer 1990/91, pp. 39-44.
- "The Human Genome Project: for better or for worse?", *Medical Journal of Australia*, vol. 152, no. 9, May 1990, pp. 484-486.
- "Clone Hype", *The Bulletin*, 9 Nov. 1993, pp. 72-78.
- "To build or be built: is that the new question?", *Search*, vol. 25, no. 4, May 1994, pp. 123-126.
- "The Challenge of Genetic Engineering", *IPARReview*, vol. 45, no. 2, 1992, pp. 20-23.
- "Existence without life: disability and genetics", *Australian Disability Review*, no. 1, 1995, pp. 3-16.
- "Some ethical issues associated with genetic engineering for people with disabilities", *Australian Disability Review*,

no. 2, 1992, pp. 12-13.

References: Information Sources

- Australian GeneEthics Network, c/- Australian Conservation Foundation, 340 Gore St, Fitzroy, Vic. 3065, Australia; ph (03) 9416 2222; fax (03) 9436 0767; e-mail: acfgenet@peg.apc.org
- Friends of the Earth, Victoria, ph (03) 9419 8700.
- Genetic Resources Action International, Jonquers 16-6-D, E-08003 Barcelona, Spain.
- Rural Advancement Foundation International: Australia, ph (079) 39 4792, e-mail: rafiaus@peg.apc.org, web site: <http://www.charm.net/rafi/rafihome.html>; International office, ph (613) 567 6880, e-mail: rafican@rafi.ca; USA, ph (919) 542 1396, e-mail: [communique@rafiusa.org](mailto:communique@rafiusa.org)
- Union of Concerned Scientists, UCS Agriculture and Biotechnology Program, 1616 P. St, NW, Washington, DC 20036, USA.

References: Web Sites

- Human Genome Organization (HUGO): [http://www.er.doe.gov/production/ohcr/hug\\_top.html](http://www.er.doe.gov/production/ohcr/hug_top.html)
- Human Genome Summit 1996, Canberra, Australia: <http://hugo.gdb.org/summit96.html>
- Monsanto: <http://www.monsanto.com/monpub/newstuff.html>
- National Institutes of Health, USA: <http://www.ncib.nm.nih.gov/science96>
- Novartis: <http://www.novartis.com/textsite/index.html>
- UNESCO International Bioethics Committee: <http://www.unesco.org/ibc>

About the Author:

Susan Bryce is a freelance investigative journalist whose interests include environmental health, technology and global politics. Based in southeast Queensland, Australia, she is available for public speaking engagements.

Continued from page 58

#### POSTSCRIPT

The following message was relayed in 1993 to writer Peter Dawkins, a student of Francis Bacon and the Master R. It begs the question, "Where is the Master R. now?"

*My name is a mask.*

*I am one yet more than one.*

*My name is a cipher: it is 1.90 and 9.3.*

*C.R.C. is an epigram.*

*Saint-Germain is a pseudonym.*

*My life is my own, yet my life is that of all souls,*

*a parable of what is, what was and what may be.*

*My life is my work and my love.*

*I cannot name myself,*

*as the intention of my work is that you should seek,*

*and by seeking discover me,*

*and by discovering me, know me.*

*My essence is silence,*

*like the voiceless fragrance of a Rose.*

*Who can name Silence?*

#### Endnotes

1. Smedley, W. T., *The Mystery of Francis Bacon*, p. 98.
2. Bacon, Francis, *Novum Organum*, London, 1620.
3. Dodd, Alfred, *Francis Bacon's Personal Life-Story*, Century Hutchinson Ltd, London, 1986, p. 101.
4. References to the Bacon-Shakespeare controversy and the ciphers in Shakespeare's plays can be found in:
  - (a) Dawkins, Peter, *Arcadia*, Francis Bacon Research Trust, Warwick, UK, 1988;
  - (b) Dawkins, Peter, *Dedication to the Light*, Francis Bacon Research Trust, Warwick, 1987;
  - (c) Dodd, Alfred, *Francis Bacon's Personal Life-Story*, *ibid.*;
  - (d) Johnson, Edward D., *Francis Bacon's Maze*, Francis Bacon Society, London, UK, 1961;
  - (e) McDuff, Euan, *The Dancing Horse Will Tell You*, Eric Faulkner-Little, Shoreham-by-Sea, UK, 1974.
5. Dawkins, *Dedication to the Light*, pp. 38-39.
6. *op. cit.*, p. 42.
7. *ibid.*, p. 38.
8. Dodd, *op. cit.*, pp. 520-525.
9. *op. cit.*, p. 542.
10. Bacon, Francis, *The Advancement of Learning*, XXI, 2, 1605.
11. Bacon, Francis, *Magna Instauratio*, Preface, 1620.
12. Durant, Will, *The Story of Philosophy*, p. 142.
13. Dodd, *op. cit.*, p. 551.
14. *op. cit.*, p. 550.

#### Additional Reading

- Hall, Manly P., *Sages and Seers*, Philosophical Research Society, Los Angeles, USA, 1959.

#### About the Author:

Michael Taylor was born in 1969 in Christchurch, New Zealand. He has a degree in history and political science from Canterbury University. He works as a computer graphics artist but devotes much of his time to the study of esoteric history. He currently resides in Saint Albans, Christchurch.

#### Note:

Copies of Michael Taylor's book, *Master R: Lord of Our Civilisation*, are available at the price of AUD\$30.00, NZD\$30.00, STG£12.00, USD\$20.00 (including postage & handling) from:

The Rawley Trust  
PO Box 2831, Christchurch 8015  
New Zealand

Telephone: +64 3 366 2943

E-mail: Mike.Taylor@netaccess.co.nz

Web page: <http://users.netaccess.co.nz/Bacon-stgermain/>